



P.O. BOX 11846 TUCSON, AZ 85734
(520) 294-3292 • FAX (520) 741-2837
www.iotaengineering.com



IIS-350-U

INSTRUCTION MANUAL

IMPORTANT SAFEGUARDS

When using electrical equipment, basic safety precautions should always be followed, including the following:

READ AND FOLLOW ALL SAFETY INSTRUCTIONS

1. **DO NOT USE OUTDOORS.**
2. Do not mount near gas or electric heaters.
3. Do not use this equipment for other than its intended use.
4. The **IIS-350-U** should be mounted securely and in locations and at heights where it will not readily be subjected to tampering by unauthorized personnel.
5. The use of accessory equipment and replacement parts not recommended by IOTA Engineering, LLC may cause an unsafe condition and void the warranty.
6. The AC voltage rating of this equipment is specified on the product label. Do not connect the **IIS-350-U** equipment to any other voltage.
7. The **IIS-350-U** uses sealed valve regulated lead acid batteries. Batteries can be punctured if not handled properly, therefore use caution when servicing batteries. In the event battery acid comes in contact with eyes or skin, flush with fresh water and consult a physician immediately.
8. Install in accordance with the National Electrical Code and local regulations.
9. Installation and servicing should be performed by qualified personnel.
10. Electricians and end-users need to ensure product system compatibility before final installation.

SAVE THESE INSTRUCTIONS



THIS UNIT CONTAINS A RECHARGEABLE VALVE-REGULATED LEAD ACID BATTERY. PLEASE RECYCLE OR DISPOSE OF PROPERLY.

INSTALLATION INSTRUCTIONS

CAUTION: Before installing, make certain the A.C. power is off.

NOTE: The battery is shipped in separate packaging for ease of handling. Store the battery in a cool, dry and safe location until ready for installation. The battery may be kept in storage for up to 3 months without recharging.

CAUTION: The **IIS-350-U** is a single voltage unit. It is designed for **120V input** but is available in both a 120V output or a multi-tap output model. Before proceeding with the installation, verify that the **IIS-350-U** model you are installing matches both the AC supply and load fixtures voltages. Incorrect voltages will cause an unsafe condition, equipment failure, and may result in fire.

1. MOUNTING THE IIS-350-U

- 1) Remove the front cover of the **IIS-350-U** by removing the two (2) screws located at the top of cover.
- 2) Knock out the keyhole slots at the rear of the unit and use for mounting the **IIS-350-U** securely to the wall. There is an additional round hole for a #10 screw in the cabinet. Code requires that an additional screw be used through this hole to prevent the unit from being inadvertently lifted up off the keyhole slots. **Do not drill any holes in this unit.** If a recessed junction box is to be mounted in the wall behind the unit, make sure an unswitched AC supply of proper rated voltage is extended to the box, and that the remote wiring to the emergency fixtures is also extended to the box prior to mounting the unit. A 1/2" conduit knockout is provided in the back of the unit for wires to pass through. 16" of wire should be routed into the unit from the recessed junction box. **NOTE:** Input and output wires must be run in separate conduits. **CAUTION:** Do not drill holes into the cabinet; drill filings may damage the unit and keep it from operating. If larger knockouts are required, use a chassis-punch through the appropriate knockout to punch out a larger knockout.
- 3) If the wiring is to be external to the wall, extend both the unswitched supply and the load wires to the unit at this time.

CAUTION: The **IIS-350-U** must be mounted securely. Do not rely on the junction box for supporting the weight of the unit. Mount the **IIS-350-U** securely to the wall using the keyhole slots provided.

ALWAYS CONSULT LOCAL CODES FOR STRUCTURAL REQUIREMENTS WHEN MOUNTING THE UNIT.

2. WIRING

1. CONNECTING THE NORMAL AC INPUT

- A. For **120V** supply, connect the AC line wire to the BLACK lead.
- B. Connect the Neutral wire to the WHITE lead.
- C. Connect the ground wire in accordance with local code. A Ground Wire is provided for this purpose.

DO NOT ENERGIZE THE CIRCUIT AT THIS TIME.

2. CONNECTING REMOTE EMERGENCY FIXTURES

- A. Connect remote emergency fixtures to the wires marked 'output.' If installing a 120V to 120V inverter unit, the output wires will be Violet and Gray (see FIGURE 1). If this is a multi-tap unit (see FIGURE 2), then the wires are color-coded as follows:

Common - GRAY
Line 120V - VIOLET
Line 208V - RED
Line 240V - BLUE
Line 277V - YELLOW

Select the proper voltage lead and cap all unused leads.

NOTE: All remote circuitry is to be wired in accordance with Article 700 of the National Electric Code. Do not exceed the total rating of the **IIS-350-U**. See equipment label for proper rating.

- B. Connect the Fixture Supply Ground to the **IIS-350-U** Ground.

FIGURE 1 - IIS-350-U WIRING CONNECTIONS FOR 120V LOAD

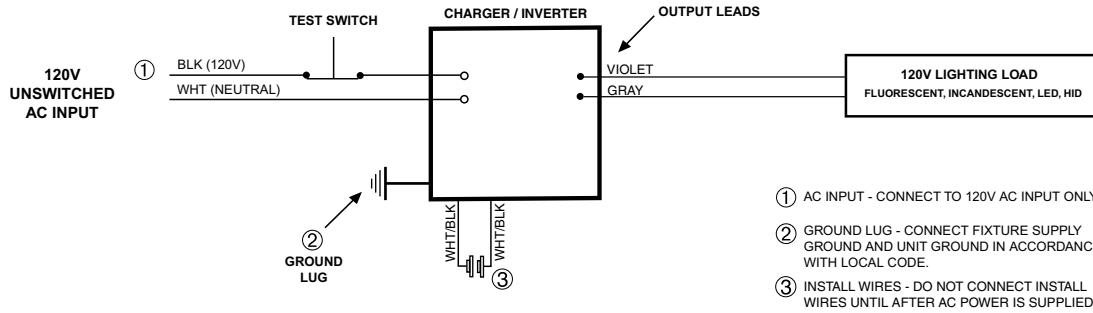
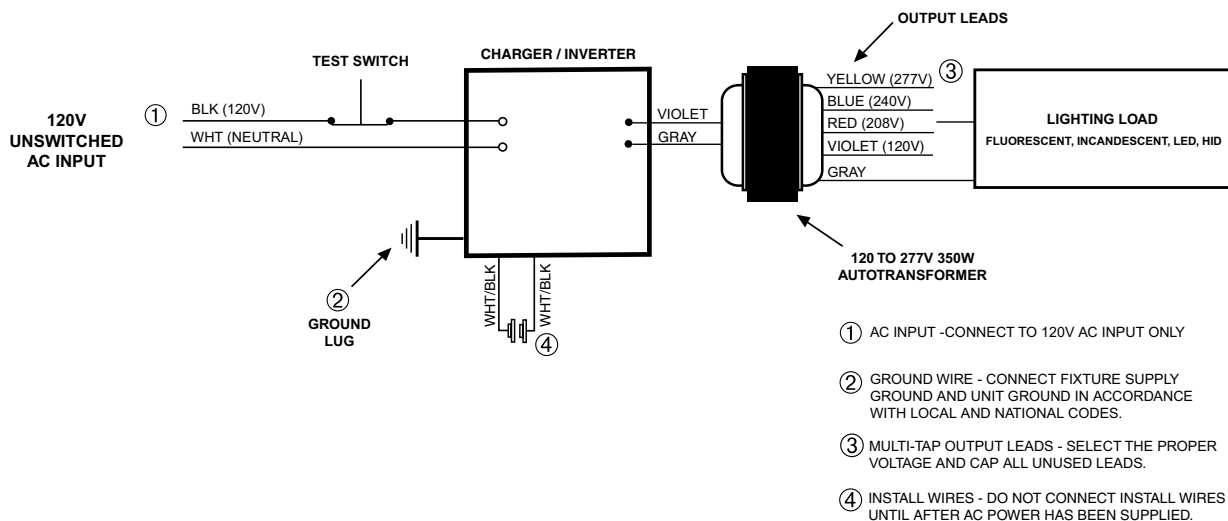

FIGURE 2 - IIS-350-UM WIRING CONNECTIONS FOR 120V, 208V, 240V AND 277V LOADS



Consult the IIS-350-U **Application Notes** for connecting the unit to specific lighting loads. Application Notes are available on the internet or through Customer Service.

DO NOT ENERGIZE THE CIRCUIT AT THIS TIME.

CAUTION: Before proceeding to Wiring Step 3, make sure that all unused wires are properly capped. Failure to do so may result in an unsafe condition and equipment failure.

3. INSTALLING THE BATTERY

A. Before installing the battery, check the torque on the hardware that connects the polarized connector to the terminals as these connections may have loosened in transit and storage. The proper torques should be 70 in/lbs for a **Screw Stud** terminal, and 65 in/lbs for an **L Flag** terminal.

B. Install the battery into the **IIS-350-U** with the terminal posts facing toward the front of the unit. NOTE: The **IIS-350-U** battery is heavy. To avoid injury, exercise caution when handling the battery.

C. Plug the battery connector together.

Note: Always apply proper torque to battery connections:

For Screw Stud batteries, initial torque is 70 in/lbs, annual is 65 in/lbs.

For L-Flag batteries, initial torque is 65 in/lbs, annual is 52 in/lbs.

NOTE: The emergency indicator lights will not illuminate at this time.

4. COMPLETING INSTALLATION

- A. Energize the AC supply. The Ready (Yellow) Indicator will illuminate and the Inverter On (Green) Indicator will be off. Mate the install wires on the left side of the unit. The Inverter On (Green) Indicator will illuminate at this time. The Alarm (Red) Indicator will be out.
- B. Operate the Test Switch for approximately 10 seconds. Observe that any emergency fixtures do not go out, then release the Test Switch.
- C. Reinstall the front cover using all the original hardware.
- D. Affix red "EMERGENCY CIRCUIT" label (provided) to the panelboard dead front cover near the circuit breaker feeding the **IIS-375-I**.

3. OPERATION

Normal Mode - AC power is present and operates the fixtures as intended. The **IIS-350-U** is in the standby charging mode. The Ready (Yellow) Indicator will be lit providing a visual indication that the unit is in Standby Mode.

Emergency Mode - The AC power fails. The **IIS-350-U** senses the AC power failure and automatically switches to the *Emergency Mode*. All fixtures connected to the **IIS-350-U** will be illuminated for a minimum of 90 minutes. When the AC power is restored, the **IIS-350-U** switches the system back to the *Normal Mode* and resumes battery charging. See page 1 of the instruction manual for important operational safeguards and requirements.

4. TESTING

- 1) To test the equipment, depress the test switch. The Ready (Yellow) Indicator will go off. The designated fixtures will stay on and the Inverter On (Green) Indicator will remain lit.
- 2) Release the Test Switch. The Ready (Yellow) Indicator will come on.

The equipment is supplied with an automatic solid state charger designed to fully recharge the battery within 24 hours after AC power is restored, and then maintain the battery in a fully charged state. Allow the battery to charge for a minimum of 24 hours after installation or power failure before conducting a 90 minute discharge test. The Life Safety Code and the Authorities Having Jurisdiction require that this test be performed on an annual basis.

5. MAINTENANCE

1. **Alarm Indicator** - Safety features within the **IIS-350-U** will force the unit to shut down under certain conditions. The red alarm indicator on the **IIS-350-U** will flash and the unit will shutdown in the event of over-voltage, low voltage, over-temperature, or system overload. In the event of a shutdown, contact Customer Service to troubleshoot for possible causes.
2. **CAUTION:** Always turn off the AC supply to the equipment, unmate the install wires and disconnect the battery before servicing. Only qualified service technicians should service this equipment. The use of parts supplied by other than IOTA Engineering, LLC may result in an unsafe condition, equipment failure and will void the warranty.
3. **BATTERY** - The battery supplied in this equipment is a high quality maintenance-free Valve Regulated Lead Acid design. It requires no maintenance and when installed in an ambient temperature of 20°-30° C (68°-86° F) its life expectancy is 8 to 10 years. However, as stated above, the equipment must be tested for 90 minutes a minimum of once per year. When the battery will no longer operate the load for 90 minutes it must be replaced. Replace only with IOTA Engineering, LLC supplied parts. Dispose or recycle the lead-acid battery properly.

CONTACT CUSTOMER SERVICE FOR REPLACEMENT PARTS.

"Written records of testing shall be kept by the owner for inspection by the authority having jurisdiction."

SERVICING SHOULD BE PERFORMED BY QUALIFIED PERSONNEL.

Consult Customer Service or visit www.iotaengineering.com for current warranty information.

BATTERY TORQUE SPECIFICATIONS

**FIGURE 1:
ROUND TERMINALS**
(100 in. - lbs)

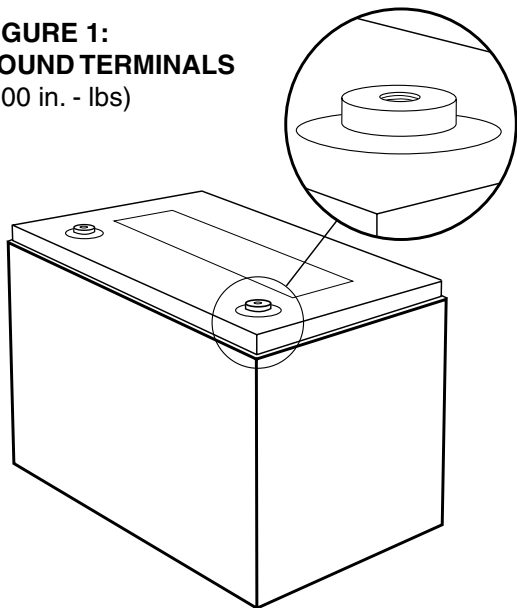

**FIGURE 2:
SQUARE TERMINALS**
(65 in. - lbs)

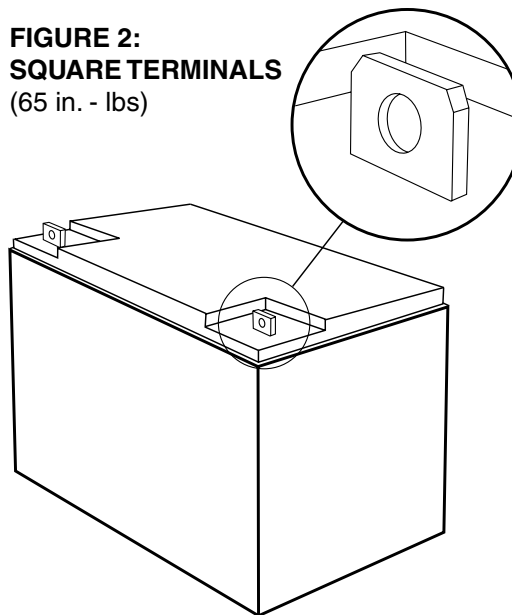

The batteries are shipped with the harness connected to the battery terminals at the proper torque specifications for the terminal type. If, for any reason, the harness must be reconnected to the terminals, refer to the specifications below for the proper torque for the terminal type:

Round Terminals - **100 in. - lbs**

Square Terminals - **65 in. - lbs**