

## INSTRUCTION MANUAL

### IMPORTANT SAFEGUARDS

When using electrical equipment, basic safety precautions should always be followed, including the following:

#### READ AND FOLLOW ALL SAFETY INSTRUCTIONS

1. **CAUTION** – To prevent electrical shock, do not mate unit connector until installation is complete and A.C. power is supplied to the unit.
2. **CAUTION** – This fixture provides more than one power supply output source. To reduce the risk of electrical shock, disconnect both normal and emergency sources by turning off the A.C. branch circuit and by disconnecting the unit connector.
3. **CAUTION** – The integral, high temperature Ni-Cad battery is replaceable. To replace the battery, disconnect the unit connector and remove both switched and unswitched A.C. power to the fixture. Remove the lid screw and open the lid to expose the battery. Unplug the battery connector and replace with part number 44203-412 (14.4V Ni-Cad battery only). Recycle or dispose of the used nickel-cadmium battery properly.
4. **DO NOT USE OUTDOORS.** The **I-160-AC-L** is for use with grounded, UL Listed, indoor fixtures except in heated air outlets or hazardous locations. The acceptability of the combination must be determined by Underwriters Laboratories. Refer to the Engineering Considerations section for proper installation.
5. The **I-160-AC-L** requires an unswitched A.C. power source of either 120 or 277 volts. Properly cap the unused A.C. lead.
6. Do not mount near gas or electric heaters.
7. The **I-160-AC-L** should be mounted in locations and at heights where it will not readily be subjected to tampering by unauthorized personnel.
8. The **I-160-AC-L** is for use with unusually shaped fluorescent fixtures such as wall packs, sconces, and recessed stair fixtures.
9. The **I-160-AC-L** will cold strike and operate two 42W 4 pin compact lamps for 90 minutes.
10. The **I-160-AC-L** operates lamps as follows:  
Two 42W 4-pin lamps for 90 minutes at reduced light output.
11. The use of accessory equipment not recommended by the manufacturer may cause an unsafe condition.
12. Do not use this equipment for other than intended use.
13. Install in accordance with the National Electrical Code and local regulations.
14. Installation and servicing should be performed by qualified personnel.
15. Lighting fixture manufacturers, electricians, and end-users need to ensure product system compatibility before final installation.

SAVE THESE INSTRUCTIONS



THIS UNIT CONTAINS A  
RECHARGEABLE NICKEL-  
CADMIUM BATTERY. PLEASE  
RECYCLE OR DISPOSE OF  
PROPERLY.

# ENGINEERING CONSIDERATIONS

**Use** - For use only in complete equipment or final applications where the acceptability of the combination is determined by Underwriters Laboratories, Inc.

These components have been judged on the basis of the required spacings in the Standard for Emergency Lighting and Power Equipment UL 924, Sec. 29, which covers the end use product for which the component was designed.

## CONDITIONS OF ACCEPTABILITY

1. Installed in a suitable ultimate enclosure.
2. Used with marked electrical rating.
3. Provide with proper spacing between live parts and enclosure and/or adjacent devices.
4. Factory wired only (terminations not suitable for field wiring).
5. Temperature tests may have to be repeated where battery temperature exceeds 61° C.
6. Mounted within the end-use product such that the battery is secured and the test switch operates properly when the end product is fully assembled.
7. End-use products employing one or more of these devices are to be marked in accordance with the Standard for Emergency Lighting and Power Equipment, UL 924.

# INSTALLATION INSTRUCTIONS

**CAUTION:** Before installing, make certain the A.C. power is off and the I-160-AC-L unit connector is disconnected.

## 1. LAMPS OPERATED

The **I-160-AC-L** can be used with two (2) 42W compact fluorescent lamps. Contact Customer Service with questions about specific lamps.

## 2. MOUNTING THE I-160-AC-L

Mount the **I-160-AC-L** in the ballast channel or enclosed wireway so the wire leads are not exposed, at least 1/2" away from the A.C. ballast(s). The circuit board should be placed so that no live parts are accessible during routine maintenance or relamping.

The battery should be at least 1/2" from the A.C. ballast and other heat sources. Since heat rises, try to mount the battery as low as possible. **CAUTION - Connect the battery to the unit before applying A.C. power.**

## 3. WIRING

Refer to the wiring diagram(s) on the back page for the appropriate wiring of lamp(s) and ballast. Install in accordance with the National Electrical Code and local regulations. For additional wiring diagrams consult Customer Service.

## 4. INSTALLING THE CHARGE INDICATOR

Select a convenient location on the fixture so that the **Charge Indicator** can be seen after installation. Allow for proper clearance and drill or punch a 1/2" mounting hole. Disconnect the leads from the **Charge Indicator**. Push the **Charge Indicator** into the 1/2" hole until it is firmly locked into place. Reconnect the leads, observing proper polarity (Red/Black or Red lead w/ connector to positive (+) red tab). Refer to *Illustration 1*. Make certain all leads are enclosed in an appropriate wireway.

## 5. INSTALLING A TEST SWITCH

A test switch should be mounted on the ballast channel cover of a recessed troffer, or on the side of a strip fixture, preferable adjacent to the charge indicator. Drill or punch a 1/2" mounting hole.

**Illustration 1**  
**Charge Indicator Light (LED)**

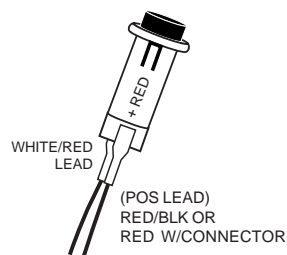

## 6. WIRING THE A.C. INPUT

The **I-160-AC-L** requires an unswitched A.C. power source of either 120 or 277 volts. Select the proper voltage lead and cap the unused lead. Refer to *Illustration 2*.

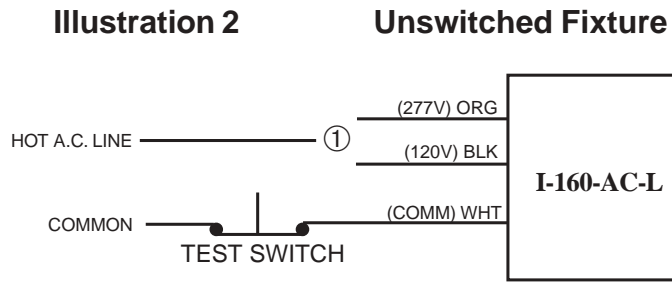

## 7. LABELS

Attach the appropriate labels adjacent to the **Test Switch** and **Charge Indicator**. Annotate Re-lamping label for lamp type and wattage. The Caution and the Re-lamping labels must be on the fixture in a readily visible location to anyone attempting to service the fixture.

## 8. COMPLETING INSTALLATION

When the installation is complete, switch the A.C. power on and join the **I-160** unit connector.

# OPERATION

**Normal Mode** – A.C. power is present. The **I-160-AC-L** is in the standby charging mode. The **Charge Indicator** will be lit providing a visual indication that the battery is being charged.

**Emergency Mode** – The A.C. power fails. The **I-160-AC-L** senses the A.C. power failure and automatically switches to the *Emergency Mode*. One or two lamps are illuminated, at reduced output, for a minimum of 90 minutes. When the A.C. power is restored, the **I-160-AC-L** switches the system back to the *Normal Mode* and resumes battery charging. See page 1 of the Instruction Manual.

# TESTING & MAINTENANCE

**Initial Testing** – Allow the unit to charge approximately 1 hour, then conduct a short discharge test. Allow a 24 hour charge before conducting a one hour test.

The **I-160-AC-L** is a maintenance free unit, however, periodic inspection and testing is required. NFPA 101, Life Safety Code, outlines the following schedule:

**Monthly** – Insure that the **Charge Indicator** light is illuminated. Conduct a 30 second discharge test by depressing the **Test Switch**. One lamp or two lamps should operate at full or reduced output, depending on your configuration.

**Annually** – Insure that the **Charge Indicator** light is illuminated. Conduct a full 1 1/2 hour discharge test. The unit should operate as intended for the duration of the test.

“Written records of testing shall be kept by the owner for inspection by the authority having jurisdiction.”

**SERVICING SHOULD BE PERFORMED BY QUALIFIED PERSONNEL.**  
Consult Customer Service or visit [www.iotaengineering.com](http://www.iotaengineering.com) for current warranty information.

# TYPICAL WIRING DIAGRAMS

For wiring diagrams of ballasts not shown, consult our Customer Service.

## WIRING FOR ONE COMPACT LAMP EMERGENCY OPERATION ONLY

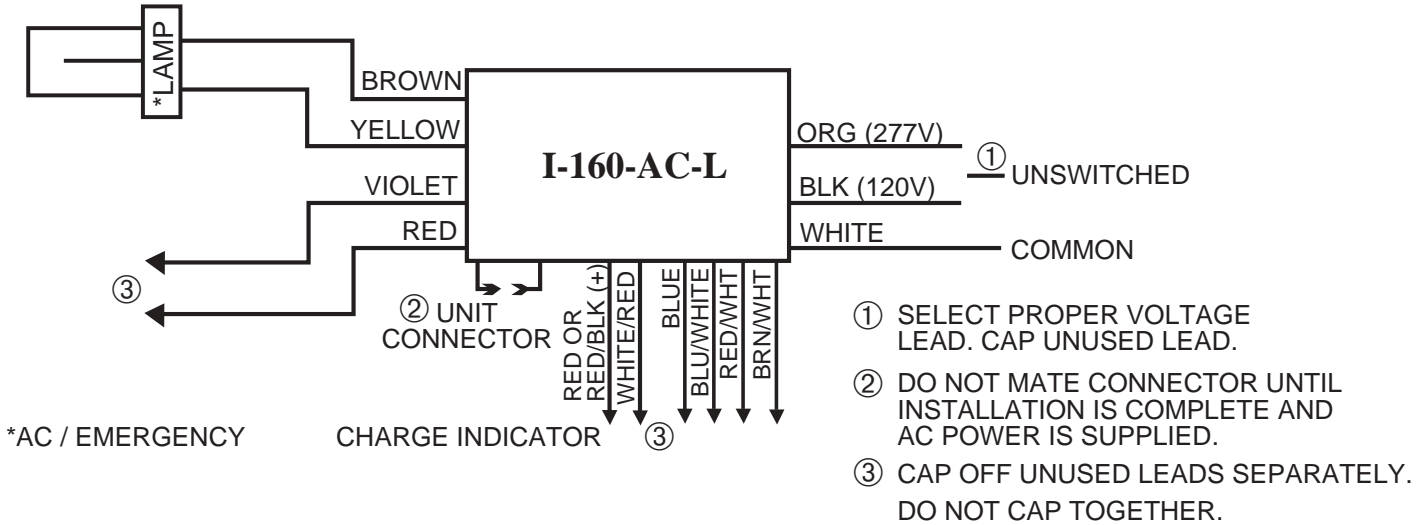

## WIRING FOR TWO COMPACT LAMPS EMERGENCY OPERATION ONLY

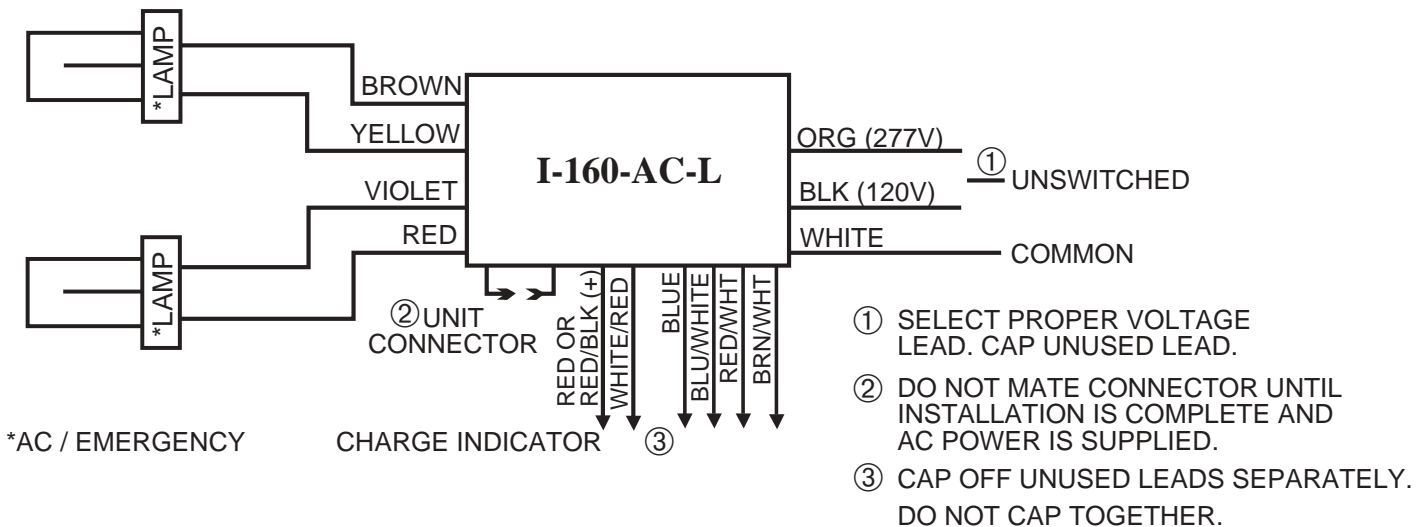

# **ATTENTION**

---

**DO NOT APPLY POWER TO THE UNIT  
UNTIL BATTERY IS CONNECTED**

# **ATTENTION**

---

**DO NOT APPLY POWER TO THE UNIT  
UNTIL BATTERY IS CONNECTED**