

P.O. BOX 11846 TUCSON, AZ 85734  
(520) 294-3292 • FAX (520) 741-2837  
www.iotaengineering.com

# I-42-L

TBTS SERIES AC  
10W-42W RAPID START  
4 PIN COMPACT LAMP  
EMERGENCY LIGHTING EQUIPMENT

## INSTRUCTION MANUAL

### IMPORTANT SAFEGUARDS

When using electrical equipment, basic safety precautions should always be followed, including the following:

#### READ AND FOLLOW ALL SAFETY INSTRUCTIONS

1. **CAUTION** – Connect the battery to the unit before applying A.C. power.
2. **CAUTION** – To prevent electrical shock, do not mate unit connector until installation is complete and A.C. power is supplied to the unit.
3. **CAUTION** – This fixture provides more than one power supply output source. To reduce the risk of electrical shock, disconnect both normal and emergency sources by turning off the A.C. branch circuit and by disconnecting the unit connector. In addition, the circuit board should be mounted so that no live parts are accessible during routine maintenance or relamping.
4. **CAUTION** – This is a sealed unit. The integral, high temperature Ni-Cad battery is not replaceable. Replace the entire unit when necessary and recycle or dispose of the nickel-cadmium battery properly.
5. The **I-42-L** is for use with grounded, UL Listed, indoor fixtures. The acceptability of the combination must be determined by Underwriters Laboratories. Refer to the Engineering Considerations section for proper installation.
6. The **I-42-L** and A.C. ballast **must** be on the same branch circuit.
7. The **I-42-L** requires an unswitched A.C. power source of either 120 or 277 volts. Properly cap the unused A.C. lead.
8. Do not mount near gas or electric heaters.
9. The **I-42-L** should be mounted in locations and at heights where it will not readily be subjected to tampering by unauthorized personnel.
10. The **I-42-L** will cold strike and operate *one* 10W through 42W, or *two* 10W through 18W, 4 pin Rapid Start compact fluorescent lamps. Contact Customer Service for additional lamp usage.
11. The **I-42-L** is for use with unusually shaped fluorescent fixtures such as wall packs, sconces, and recessed stair fixtures.
12. The use of accessory equipment not recommended by the manufacturer may cause an unsafe condition.
13. Do not use this equipment for other than intended use.
14. Install in accordance with the National Electrical Code and local regulations.
15. Installation and servicing should be performed by qualified personnel.
16. Lighting fixture manufacturers, electricians and end users need to ensure product system compatibility before final installation.

SAVE THESE INSTRUCTIONS



THIS UNIT CONTAINS A RECHARGEABLE NICKEL-CADMIUM BATTERY. PLEASE RECYCLE OR DISPOSE OF PROPERLY.

# ENGINEERING CONSIDERATIONS

**Use** – For use only in complete equipment or final applications where the acceptability of the combination is determined by Underwriters Laboratories, Inc.

These components have been judged on the basis of the required spacings in the Standard for Emergency Lighting and Power Equipment UL 924, Sec. 29, which covers the end use product for which the component was designed.

## CONDITIONS OF ACCEPTABILITY

1. Installed in a suitable ultimate enclosure.
2. Used with marked electrical ratings.
3. Provide with proper spacing between live parts and enclosure and/or adjacent devices.
4. Factory wired only (terminations not suitable for field wiring).
5. Temperature tests may have to be repeated where battery temperature exceeds 55° C.
6. Mounted within the end-use product such that the battery is secured and the test switch operates properly when the end product is fully assembled.
7. End-use products employing one or more of these devices are to be marked in accordance with the Standard for Emergency Lighting and Power Equipment, UL 924.

# INSTALLATION INSTRUCTIONS

**CAUTION:** Before installing, make certain the A.C. power is off and the I-42-L unit connector is disconnected.

## 1. LAMPS OPERATED

Refer to the chart below for the type of lamp(s) operated and the number of lamps to be operated in the emergency mode. If you have any questions regarding specific lamps, contact customer service.

OPTION	LAMP	TYPE	EMERGENCY OPERATION	VIOLET LEADS
1	10W-18W	Compact	One Lamp	Connected
2	26W-42W	Compact	One Lamp	Disconnected
3	10W-13W	Compact	Two Lamp	Connected
4	18W	Compact	Two Lamp	Disconnected
5	18W	Long Compact	One Lamp	Connected
6	24W	Long Compact	One Lamp	Disconnected
7	36W	Long Compact	One Lamp	Disconnected

The 6" violet leads provide the lamp selection option. The unit is shipped from the factory with the leads disconnected and capped. When used with particular lamp types, violet leads should be connected to one another. Refer to chart for lamp selection options.

## 2. MOUNTING THE I-42-L AND BATTERY

Mount the **I-42-L** in the ballast channel or enclosed wireway so the wire leads are not exposed, at least 1/2" away from the A.C. ballast(s). Mount the **I-42-L** using the mounting holes provided. The insulating barrier should be mounted against the fixture wall. Then the main circuit board can be mounted leaving a space between the board and the mounting barrier as shown in *Illustration 1*. The circuit board should be placed so that no live parts are accessible during routine maintenance or relamping.

The battery should be at least 1/2" from the A.C. ballast and other heat sources. Since heat rises, try to mount the battery as low as possible. **CAUTION** – Connect the battery to the unit before applying A.C. power.

**Illustration 1**

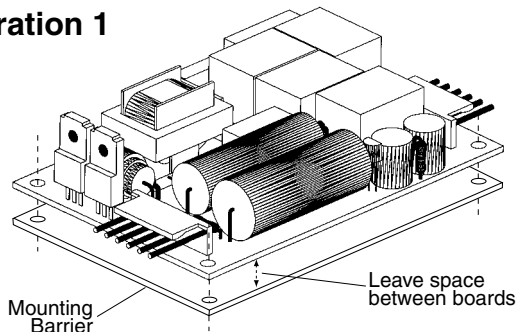

**Illustration 2 - TBTS**

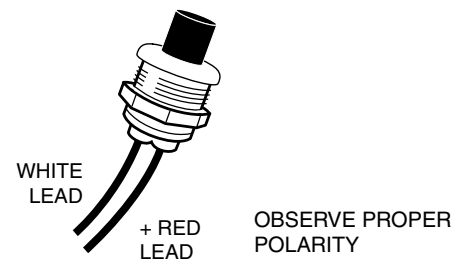

**INSURE WIRING IS IN ACCORDANCE WITH THE NATIONAL ELECTRICAL CODE AND LOCAL REGULATIONS.**

### 3. INSTALLING THE THREADED BODY TEST SWITCH (TBTS)

Select a convenient location on the side of the fixture so that the **TBTS** can be seen after installation. Allow for proper clearance and drill or punch a 1/2" hole. Remove the nut from the **TBTS**. Push the **TBTS** housing into the 1/2" hole and secure with the nut. Connect the LED wires from the unit to the **TBTS** (Red/Black or Red w/tag to Red, and White/Red to White).

### 4. WIRING

- A. The **I-42-L** and A.C. ballast **must** be on the same branch circuit.
- B. The **I-42-L** requires an **unswitched** A.C. power source of either 120 or 277 volts; therefore, when used with switched fixtures, the **I-42-L** input must be wired ahead of the switch.
- C. Refer to the wiring diagrams on the back page for the proper wiring. For wiring diagrams of ballasts not shown, consult our customer service.

### 5. LABELS

Attach the appropriate labels adjacent to the **TBTS**. Annotate Re-lamping label for lamp type and wattage. The Caution and the Re-lamping labels must be on the fixture in a readily visible location to anyone attempting to service the fixture.

### 6. COMPLETING INSTALLATION

- A. When the installation is complete, switch the A.C. power on and join the **I-42-L** unit connector.
- B. Replace the ballast cover, fixture lens and other fixture hardware.

## OPERATION

**Normal Mode** – A.C. power is present. The A.C. ballast operates the fluorescent lamp(s) as intended. The **I-42-L** is in the standby charging mode. The **TBTS** will be lit providing a visual indication that the battery is being charged.

**Emergency Mode** – The A.C. power fails. The **I-42-L** senses the A.C. power failure and automatically switches to the *Emergency Mode*. One lamp or two lamps are illuminated, at reduced output, for a minimum of 90 minutes. When the A.C. power is restored, the **I-42-L** switches the system back to the *Normal Mode* and resumes battery charging. See page 1 of the Instruction Manual.

## TESTING & MAINTENANCE

Pressing the red lens on the **TBTS** turns off the light on the **TBTS** and forces the unit into emergency mode, interrupting power to the designated A.C. ballast. The emergency lamp is now being lit by the **I-42-L** unit. After releasing the **TBTS**, the fixture returns to normal operation after a momentary delay. To simulate a "BLACK OUT" use the circuit breaker to turn off A.C. power.

**Initial Testing** – Allow the unit to charge approximately 1 hour, then conduct a short discharge test by depressing the test switch. Allow a 24 hour charge before conducting a one hour test.

The **I-42-L** is a maintenance free unit, however, periodic inspection and testing is required. NFPA 101, Life Safety Code, outlines the following schedule:

**Monthly** – Insure that the **TBTS** light is illuminated. Conduct a 30 second discharge test by depressing the **TBTS**. One lamp or two lamps should operate at reduced output.

**Annually** – Insure that the **TBTS** light is illuminated. Conduct a full 1½ hour discharge test. The unit should operate as intended for the duration of the test.

"Written records of testing shall be kept by the owner for inspection by the authority having jurisdiction."

**SERVICING SHOULD BE PERFORMED BY QUALIFIED PERSONNEL.**

Consult Customer Service or visit [www.iotaengineering.com](http://www.iotaengineering.com) for current warranty information.

# TYPICAL WIRING DIAGRAMS

Use in conjunction with Rapid Start ballasts and 4 pin lamps only

Wiring and Troubleshooting Tips are available on-line at <http://www.iotaengineering.com/wiringtips.pdf>

## 1. ONE LAMP RAPID START BALLAST

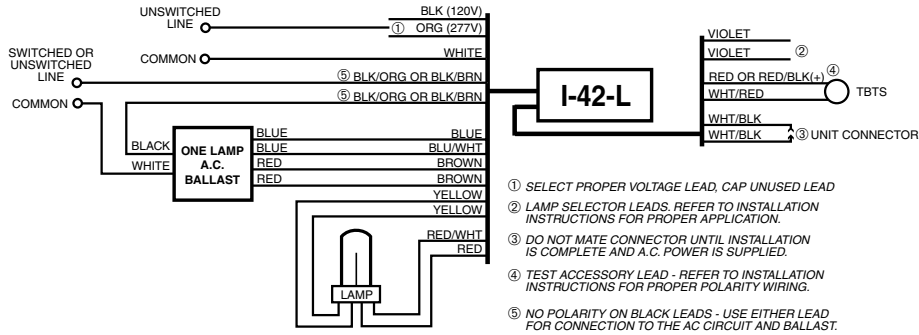

## 2. TWO LAMP RAPID START BALLAST WITH ONE LAMP EMERGENCY OPERATION

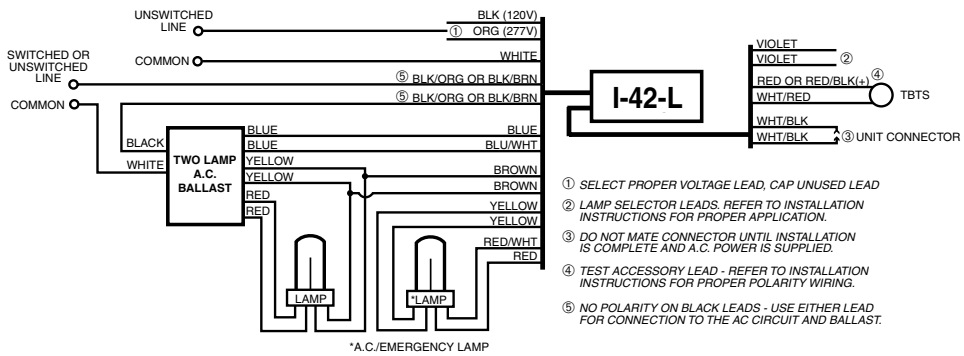

## 3. TWO LAMP RAPID START BALLAST WITH TWO LAMP EMERGENCY OPERATION

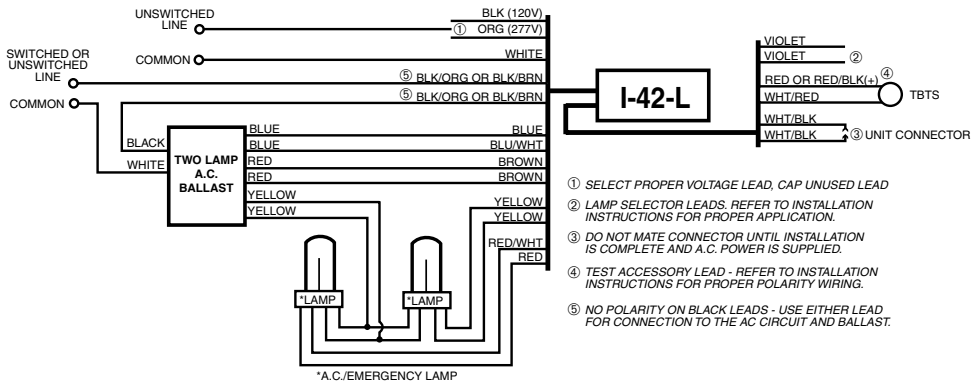

## 4. ALTERNATE TWO LAMP RAPID START BALLAST WITH ONE LAMP EMERGENCY OPERATION

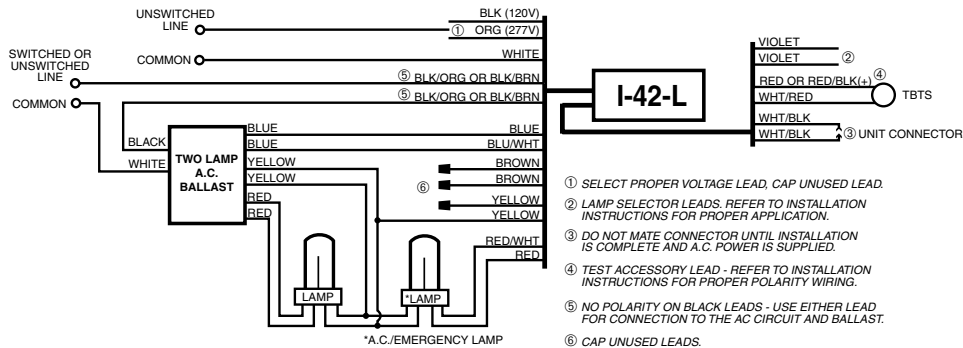

# **ATTENTION**

---

**DO NOT APPLY POWER TO THE UNIT  
UNTIL BATTERY IS CONNECTED**

# **ATTENTION**

---

**DO NOT APPLY POWER TO THE UNIT  
UNTIL BATTERY IS CONNECTED**