

INSTRUCTION MANUAL

IMPORTANT SAFEGUARDS

When using electrical equipment, basic safety precautions should always be followed, including the following:

READ AND FOLLOW ALL SAFETY INSTRUCTIONS

1. **CAUTION** – To prevent electrical shock, do not mate unit connector until installation is complete and A.C. power is supplied to the unit.
2. **CAUTION** – This fixture provides more than one power supply output source. To reduce the risk of electrical shock, disconnect both normal and emergency sources by turning off the A.C. branch circuit and by disconnecting the unit connector.
3. **CAUTION** – This is a sealed unit. The integral, high temperature Ni-Cad battery is not replaceable. Replace the entire unit when necessary and recycle or dispose of the nickel-cadmium battery properly.
4. The **ICE-420-EM-B** is for use with grounded, UL Listed, damp location rated and enclosed and gasketed fixtures. Not for use in heated air outlets or hazardous locations.
5. The **ICE-420-EM-B** requires an unswitched A.C. power source of either 120 or 277 volts. Properly cap the unused A.C. lead.
6. Do not mount near gas or electric heaters.
7. The **ICE-420-EM-B** should be mounted in locations and at heights where it will not readily be subjected to tampering by unauthorized personnel.
8. **When used in conjunction with enclosed and gasketed fixtures the ICE-420-EM-B is suitable for mounting in the ballast compartment only.**
9. The **ICE-420-EM-B** will cold strike and operate *one* 10W through 70W, or *two* 10W through 32W, 4 pin Rapid Start compact fluorescent lamps. Contact Customer Service for additional lamp usage.
10. The **ICE-420-EM-B** is compatible with most electronic A.C. ballasts (including multiple lamps) as follows:
Electronic ballasts – one or two lamp emergency operation.
11. Suitable for use in damp locations and in enclosed and gasketed fixtures.
12. For use in -18° C minimum, 50° C maximum ambient temperatures.
13. The use of accessory equipment not recommended by the manufacturer may cause an unsafe condition.
14. Do not use this equipment for other than intended use.
15. Install in accordance with the National Electrical Code and local regulations.
16. Installation and servicing should be performed by qualified personnel.
17. Lighting fixture manufacturers, electricians, and end-users need to ensure product system compatibility before final installation.

SAVE THESE INSTRUCTIONS



THIS UNIT CONTAINS A
RECHARGEABLE NICKEL-
CADMIUM BATTERY. PLEASE
RECYCLE OR DISPOSE OF
PROPERLY.

INSTALLATION INSTRUCTIONS

CAUTION: Before installing, make certain the A.C. power is off and the ICE-420-EM-B unit connector is disconnected.

1. LAMPS OPERATED

Refer to the chart below for the type of lamp(s) operated and the number of lamps to be operated in the emergency mode. If you have any questions regarding specific lamps, contact customer service.

OPTION	LAMP	TYPE	EMERGENCY OPERATION	*VIOLET LEADS	WIRING DIAGRAMS
1	10W-32W	Compact	One Lamp	Connected	1,2
2	42W-70W	Compact	One Lamp	Disconnected	1,2
3	10W-13W	Compact	Two Lamp	Connected	3
4	18W-32W	Compact	Two Lamp	Disconnected	3

*The 6" violet leads provide the lamp selection option. The unit is shipped from the factory with the leads disconnected and capped. When used with particular lamp types, violet leads should be connected to one another. Refer to chart for lamp selection options.

2. MOUNTING THE ICE-420-EM-B

Mount the **ICE-420-EM-B** in the ballast channel or enclosed wireway so the wire leads are not exposed, at least 1/2" away from the A.C. ballast(s). Refer to *Illustration 1*.

When battery packs are remote mounted, consult Customer Service for the maximum allowable distance between the battery pack and the lamp.

3. WIRING

- A. The **ICE-420-EM-B** and A.C. ballast **must** be on the same branch circuit.
- B. The **ICE-420-EM-B** requires an **unswitched** A.C. power source of either 120 or 277 volts; therefore, when used with switched fixtures, the **ICE-420-EM-B** input must be wired ahead of the switch.
- C. Refer to the wiring diagrams on the back page for the proper wiring. For wiring diagrams of ballasts not shown, consult our Customer Service.

NOTE: The **ICE-420-EM-B** will require a maximum power input of 100 watts when the internal heating element is active.

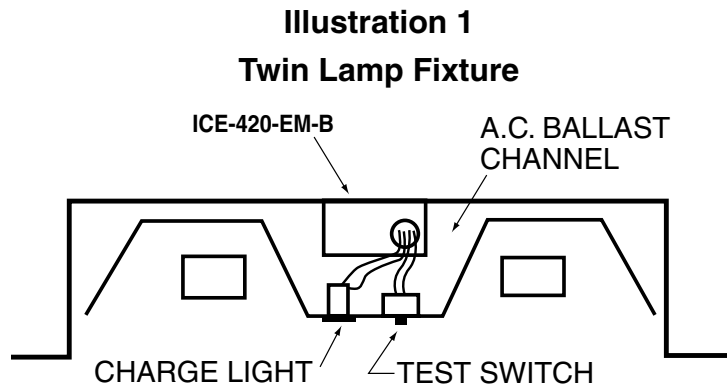

INSURE WIRING IS IN ACCORDANCE WITH THE NATIONAL ELECTRICAL CODE AND LOCAL REGULATIONS.

4. INSTALLING THE CHARGE INDICATOR

Select a convenient location on the fixture so that the **Charge Indicator** can be seen after installation. Allow for proper clearance and drill or punch a ½" mounting hole. Disconnect the leads from the **Charge Indicator** and push the **Charge Indicator** into the ½" hole until it is firmly locked into place. Reconnect the leads, observing proper polarity (Red/Black or Red lead w/connector to positive (+) red tab). Make certain all leads are enclosed in an appropriate wireway. Refer to *Illustration 1*.

5. INSTALLING THE TEST SWITCH

The **Test Switch** should be mounted on the fixture to allow access to authorized personnel. Drill or punch a ½" mounting hole. Make certain all leads are enclosed in an appropriate wireway. Refer to *Illustration 1*.

6. LABELS

Attach the appropriate labels adjacent to the **Test Switch** and **Charge Indicator**. Annotate Re-lamping label for lamp type and wattage. The Caution and the Re-lamping labels must be on the fixture in a readily visible location to anyone attempting to service the fixture.

7. COMPLETING INSTALLATION

- A. When the installation is complete, switch the A.C. power on and join the **ICE-420-EM-B** unit connector.
- B. Replace the ballast cover, fixture lens and other fixture hardware.

OPERATION

General – This unit is primarily designed to be used with compact fluorescent lamp downlight fixtures. It will wire in conjunction with the existing A.C. ballast(s) and lamp(s) to provide the emergency function. It can also be wired for emergency only operation.

Normal Mode – A.C. power is present. The A.C. ballast operates the fluorescent lamp(s) as intended. The **ICE-420-EM-B** is in the standby charging mode. The **Charge Indicator** will be lit providing a visual indication that the battery is being charged.

Emergency Mode – The A.C. power fails. The **ICE-420-EM-B** senses the A.C. power failure and automatically switches to the *Emergency Mode*. One lamp or two lamps are illuminated, at reduced output, for a minimum of 90 minutes. When the A.C. power is restored, the **ICE-420-EM-B** switches the system back to the *Normal Mode* and resumes battery charging. See page 1 of the Instruction Manual.

TESTING & MAINTENANCE

Pressing the **Test Switch** turns off the light on the **Charge Indicator** and forces the unit into emergency mode, interrupting power to the designated A.C. ballast. The emergency lamp is now being lit by the **ICE-420-EM-B** unit. After releasing the **Test Switch**, the fixture returns to normal operation after a momentary delay. To simulate a "BLACK OUT" use the circuit breaker to turn off A.C. power.

Initial Testing – Allow the unit to charge approximately 1 hour, then conduct a short discharge test by depressing the **Test Switch**. Allow a 24 hour charge before conducting a one hour test.

The **ICE-420-EM-B** is a maintenance free unit, however, periodic inspection and testing is required. NFPA 101, Life Safety Code, outlines the following schedule:

Monthly – Insure that the **Charge Indicator** light is illuminated. Conduct a 30 second discharge test by depressing the **Test Switch**. One lamp or two lamps should operate at reduced output.

Annually – Insure that the **Charge Indicator** light is illuminated. Conduct a full 1½ hour discharge test. The unit should operate as intended for the duration of the test.

"Written records of testing shall be kept by the owner for inspection by the authority having jurisdiction."

SERVICING SHOULD BE PERFORMED BY QUALIFIED PERSONNEL.
Consult Customer Service or visit www.iotaengineering.com for current warranty information.

TYPICAL WIRING DIAGRAMS

Use in conjunction with Rapid Start ballasts and 4 pin lamps only

1. ONE LAMP RAPID START BALLAST

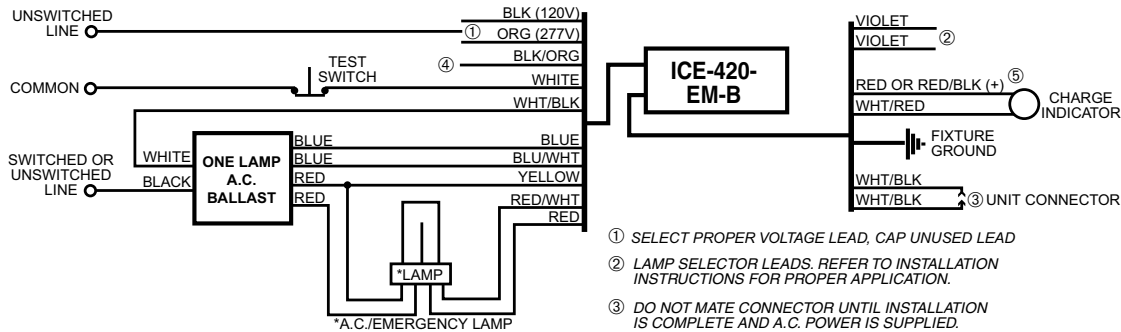

- ① SELECT PROPER VOLTAGE LEAD, CAP UNUSED LEAD
- ② LAMP SELECTOR LEADS. REFER TO INSTALLATION INSTRUCTIONS FOR PROPER APPLICATION.
- ③ DO NOT MATE CONNECTOR UNTIL INSTALLATION IS COMPLETE AND A.C. POWER IS SUPPLIED.
- ④ FOR 120V INSTALLATION, CONNECT BLK/ORG TO BLK. FOR 277V INSTALLATION, CAP BLK/ORG AND BLK SEPARATELY.
- ⑤ TEST ACCESSORY LEADS-REFER TO INSTALLATION INSTRUCTIONS FOR PROPER POLARITY WIRING.

2. TWO LAMP RAPID START BALLAST WITH ONE LAMP EMERGENCY OPERATION

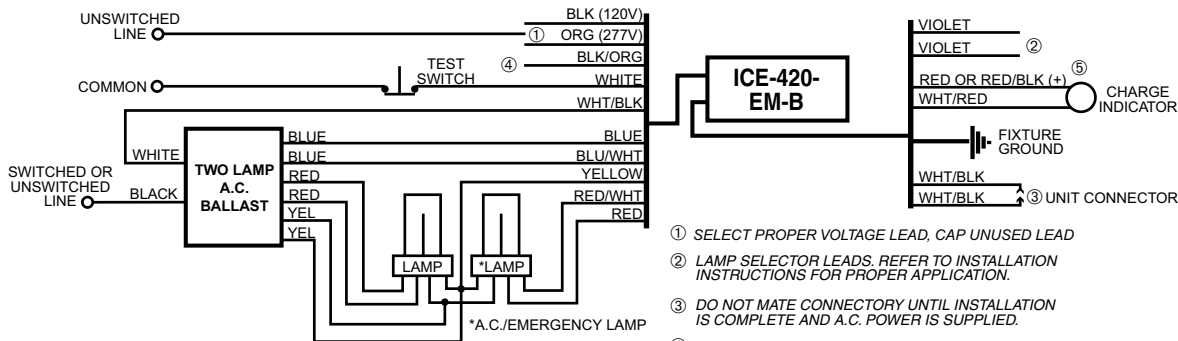

- ① SELECT PROPER VOLTAGE LEAD, CAP UNUSED LEAD
- ② LAMP SELECTOR LEADS. REFER TO INSTALLATION INSTRUCTIONS FOR PROPER APPLICATION.
- ③ DO NOT MATE CONNECTOR UNTIL INSTALLATION IS COMPLETE AND A.C. POWER IS SUPPLIED.
- ④ FOR 120V INSTALLATION, CONNECT BLK/ORG TO BLK. FOR 277V INSTALLATION, CAP BLK/ORG AND BLK SEPARATELY.
- ⑤ TEST ACCESSORY LEADS-REFER TO ISNTALLATION INSTRUCTIONS FOR PROPER POLARITY WIRING.

3. TWO LAMP RAPID START BALLAST WITH TWO LAMP EMERGENCY OPERATION

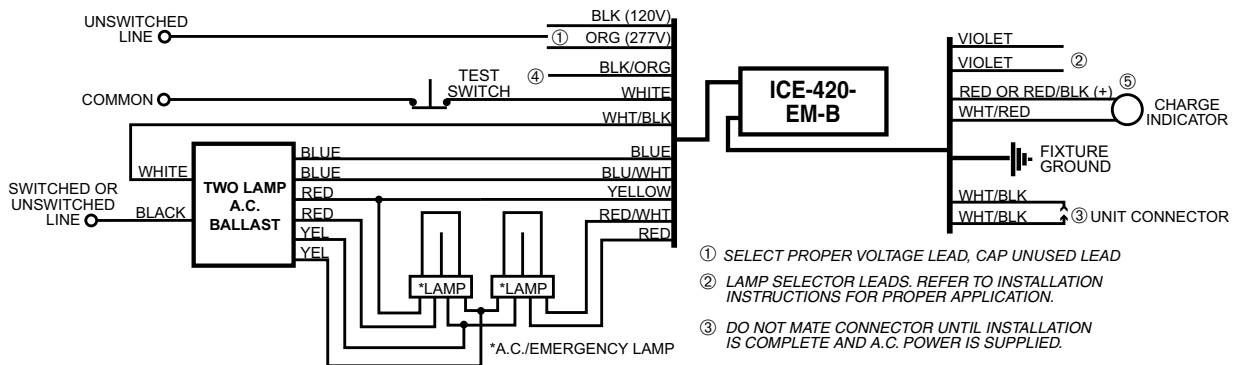

- ① SELECT PROPER VOLTAGE LEAD, CAP UNUSED LEAD
- ② LAMP SELECTOR LEADS. REFER TO INSTALLATION INSTRUCTIONS FOR PROPER APPLICATION.
- ③ DO NOT MATE CONNECTOR UNTIL INSTALLATION IS COMPLETE AND A.C. POWER IS SUPPLIED.
- ④ FOR 120V INSTALLATION, CONNECT BLK/ORG TO BLK. FOR 277V INSTALLATION, CAP BLK/ORG AND BLK SEPARATELY.
- ⑤ TEST ACCESSORY LEADS-REFER TO INSTALLATION INSTRUCTIONS FOR PROPER POLARITY WIRING.