

INSTRUCTION MANUAL

IMPORTANT SAFEGUARDS

When using electrical equipment, basic safety precautions should always be followed, including the following:

READ AND FOLLOW ALL SAFETY INSTRUCTIONS

1. **CAUTION** – To prevent electrical shock, do not mate unit connector until installation is complete and A.C. power is supplied to the unit.
2. **CAUTION** – This fixture provides more than one power supply output source. To reduce the risk of electrical shock, disconnect both normal and emergency sources by turning off the A.C. branch circuit and by disconnecting the unit connector.
3. **CAUTION** – The integral, high temperature Ni-Cad battery is replaceable. To replace the battery, disconnect the unit connector and remove both switched and unswitched A.C. power to the fixture. Remove the lid screw and open the lid to expose the battery. Unplug the battery connector and replace with part number 44203-412 (14.4V Ni-Cad battery only). Recycle or dispose of the used nickel-cadmium battery properly
4. **DO NOT USE OUTDOORS.** The I-162 is for use with grounded, UL Listed, indoor fixtures. Do not use in heated air outlets or hazardous locations.
5. The I-162 requires an unswitched A.C. power source of either 120 or 277 volts. Properly cap the unused A.C. lead.
6. The I-162 and A.C. ballast **must** be on the same branch circuit.
7. Do not mount near gas or electric heaters.
8. The I-162 should be mounted in locations and at heights where it will not readily be subjected to tampering by unauthorized personnel.
9. The I-162 mounts on top of the fixture or adjacent to the fixture on an optional T-bar mounting bracket.
10. The I-162 will cold strike and operate *two* 4' instant start, rapid start, U shape or circline fluorescent lamps, T8 through T12 fluorescent lamps, *two* 54W T5 fluorescent lamps, or *two* 26W-57W compact fluorescent lamps.
11. The I-162 operates lamps as follows:
Two 4' T8-T12 lamps, two 54W T5 lamps, or two 26W-57W compact lamps for 90 minutes.
12. The use of accessory equipment not recommended by the manufacturer may cause an unsafe condition.
13. Do not use this equipment for other than intended use.
14. Install in accordance with the National Electrical Code and local regulations.
15. Installation and servicing should be performed by qualified personnel.
16. Lighting fixture manufacturers, electricians, and end-users need to ensure product system compatibility before final installation.

SAVE THESE INSTRUCTIONS



THIS UNIT CONTAINS A RECHARGEABLE NICKEL-CADMIUM BATTERY. PLEASE RECYCLE OR DISPOSE OF PROPERLY.

INSTALLATION INSTRUCTIONS

CAUTION: Before installing, make certain the A.C. power is off and the I-162 unit connector is disconnected.

1. MOUNTING THE I-162

Remove the ballast channel cover. Mount the **I-162** on the fixture top in a position that does not interfere with the existing A.C. ballast or any other hardware. Extend the flex conduit to a convenient location on top of the fixture and punch a $\frac{7}{8}$ " hole. Feed the wires and flex connector down through the hole in the fixture and secure in place with the flex connector nut. An optional T-bar mounting kit is available to mount the **I-162** above the ceiling tile adjacent to the emergency fixture. To order the optional T-bar mounting kit (part number TBMK-160) contact Customer Service.

When used with ceiling mounted downlight fixtures, the **I-162** should be mounted on the fixture above the ceiling or on the optional T-bar mounting kit. The flex conduit should be wired into the ballast/lamp compartment or to an electrical junction box on the fixture which allows access to the ballast/lamp connections. Refer to *Illustration 2* for typical mounting.

When battery packs are remote mounted, consult Customer Service for the maximum allowable distance between the battery pack and lamp.

CAUTION: Properly secure the **I-162** in the ceiling grid to insure compliance with local, state, and federal guidelines regarding ceiling mounted equipment.

3. WIRING

Refer to the wiring diagrams on the back page for the appropriate wiring of lamp(s) and ballast. Install in accordance with the National Electrical Code and local regulations. For additional wiring diagrams consult Customer Service.

4. INSTALLING THE CHARGE INDICATOR

Recessed Troffer Fixture – Select a convenient location with proper clearance in the ballast cover and drill or punch a $\frac{7}{8}$ " hole ($\frac{1}{2}$ " knockout). Insert the $\frac{7}{8}$ " bushing into the hole. Push the plastic tube through the bushing. Disconnect the leads from the **LED** housing and route the leads down the plastic tube. Reconnect the leads to the housing, observing the proper polarity (Red/Black or Red lead w/connector to positive (+) red tab). Push the entire assembly back into the tube until the lens collar rests against the plastic tube. The plastic tube should be adjusted so that the **Charge Indicator** is within $\frac{1}{4}$ " of the fixture lens. The **Charge Indicator** must be visible after installation. Refer to *Illustration 1*.

Ceiling-Mounted Downlight Fixture – Select a convenient location on the side of the fixture so the **Charge Indicator** can be seen after installation. Allow for proper clearance inside the fixture and drill or punch a $\frac{1}{2}$ " hole. Disconnect the leads from the **LED** housing. Push the **LED** housing into the $\frac{1}{2}$ " hole until it is firmly locked in place. Reconnect the leads, observing the proper polarity (Red/Black or Red lead w/connector to positive (+) red tab). Refer to *Illustration 2*. For remote mounting the charge indicator and test switch, the optional RTK accessory kit can be ordered.

5. INSTALLING THE TEST SWITCH

The test switch should be mounted on the ballast channel cover of a recessed troffer, or on the side of a strip fixture, preferably adjacent to the charge indicator. Drill or punch a $\frac{1}{2}$ " mounting hole. Refer to *Illustration 2*.

6. WIRING THE A.C. INPUT

- The **I-162** and A.C. ballast **must** be on the same branch circuit.
- The **I-162** requires an **unswitched** A.C. power source of either 120 or 277 volts. Select the proper voltage lead and cap the unused lead.
- When the **I-162** is used with a switched fixture, the A.C. input to the **I-162** must be connected ahead of the fixture switch. Refer to *Illustration 3* for switched and unswitched fixture wiring diagrams.

Illustration 1 Recessed Troffer Fixture

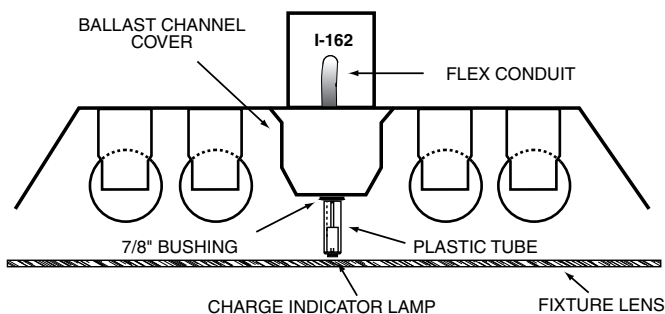
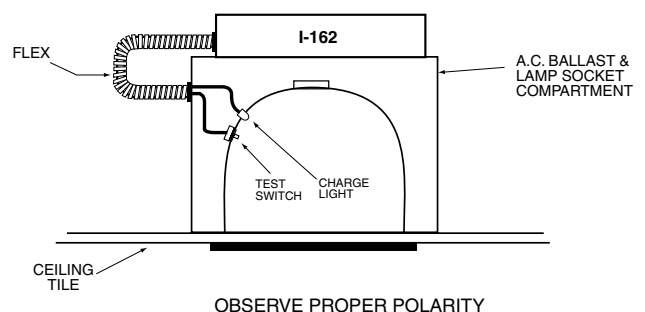

Illustration 2 Downlight Fixture



7. LABELS

Attach the appropriate labels adjacent to the **Test Switch** and **Charge Indicator**. Annotate Re-lamping label for lamp type and wattage. The Caution and the Re-lamping labels must be on the fixture in a readily visible location to anyone attempting to service the fixture.

8. COMPLETING INSTALLATION

When the installation is complete, switch the A.C. power on and join the **I-162** unit connector.

Illustration 3 Switched Fixture

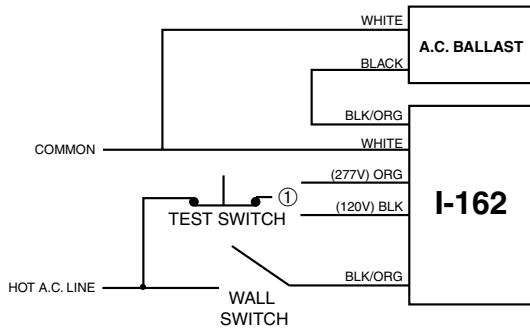

① Select proper voltage lead. Cap unused lead.

Unswitched Fixture

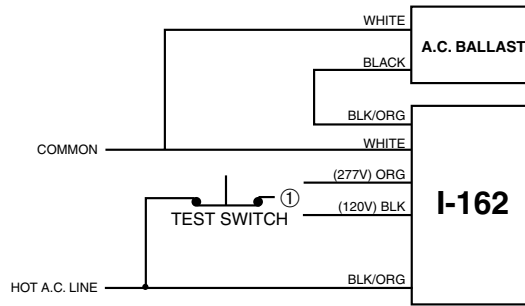

① Select proper voltage lead. Cap unused lead.

OPERATION

Normal Mode – A.C. power is present. The A.C. ballast operates the fluorescent lamp(s) as intended. The **I-162** is in the standby charging mode. The **Charge Indicator** will be lit providing a visual indication that the battery is being charged.

Emergency Mode – The A.C. power fails. The **I-162** senses the A.C. power failure and automatically switches to the *Emergency Mode*. One or two lamps are illuminated, at reduced output, for a minimum of 90 minutes. When the A.C. power is restored, the **I-162** switches the system back to the *Normal Mode* and resumes battery charging. See page 1 of the Instruction Manual.

TESTING & MAINTENANCE

Initial Testing – Allow the unit to charge approximately 1 hour, then conduct a short discharge test. Allow a 24 hour charge before conducting a one hour test.

The **I-162** is a maintenance free unit, however, periodic inspection and testing is required. NFPA 101, Life Safety Code, outlines the following schedule:

Monthly – Insure that the **Charge Indicator** light is illuminated. Conduct a 30 second discharge test by depressing the **Test Switch**. One lamp or two lamps should operate at full or reduced output, depending on your configuration.

Annually – Insure that the **Charge Indicator** light is illuminated. Conduct a full 1½ hour discharge test. The unit should operate as intended for the duration of the test.

“Written records of testing shall be kept by the owner for inspection by the authority having jurisdiction.”

SERVICING SHOULD BE PERFORMED BY QUALIFIED PERSONNEL.
Consult Customer Service or visit www.iotaengineering.com for current warranty information.

TYPICAL WIRING DIAGRAMS

For wiring diagrams of ballasts not shown, consult our Customer Service.

Wiring and Troubleshooting Tips are available on-line at <http://www.iotaengineering.com/wiringtips.pdf>

1. TWO LAMP RAPID START BALLAST

* OPERATES IN A.C. AND EMERGENCY MODE.

- ① SELECT PROPER VOLTAGE LEAD. CAP UNUSED LEADS.
- ② DO NOT MATE CONNECTOR UNTIL INSTALLATION IS COMPLETE AND A.C. POWER IS SUPPLIED.
- ③ TEST ACCESSORY LEADS - REFER TO INSTALLATION INSTRUCTIONS FOR PROPER POLARITY LEAD WIRING.
- ④ NO POLARITY ON BLK/ORG LEADS.
- ⑤ SWITCHED OR UNSWITCHED LINE- REFER TO INSTALLATION MANUAL FOR HOT AND TEST SWITCH PLACEMENT.

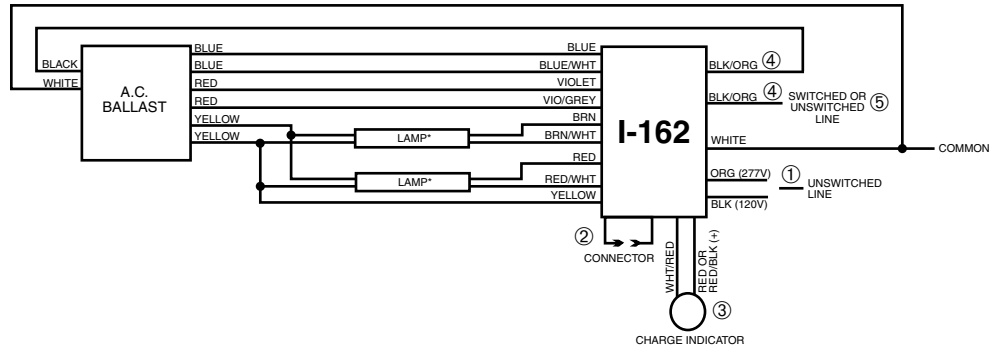

2. TWO LAMP INSTANT START BALLAST

* OPERATES IN A.C. AND EMERGENCY MODE.

- ① SELECT PROPER VOLTAGE LEAD. CAP UNUSED LEADS.
- ② DO NOT MATE CONNECTOR UNTIL INSTALLATION IS COMPLETE AND A.C. POWER IS SUPPLIED.
- ③ PIGTAIL LEADS TOGETHER.
- ④ TEST ACCESSORY LEADS - REFER TO INSTALLATION INSTRUCTIONS FOR PROPER POLARITY LEAD WIRING.
- ⑤ NO POLARITY ON BLK/ORG LEADS.
- ⑥ SWITCHED OR UNSWITCHED LINE- REFER TO INSTALLATION MANUAL FOR HOT AND TEST SWITCH PLACEMENT.

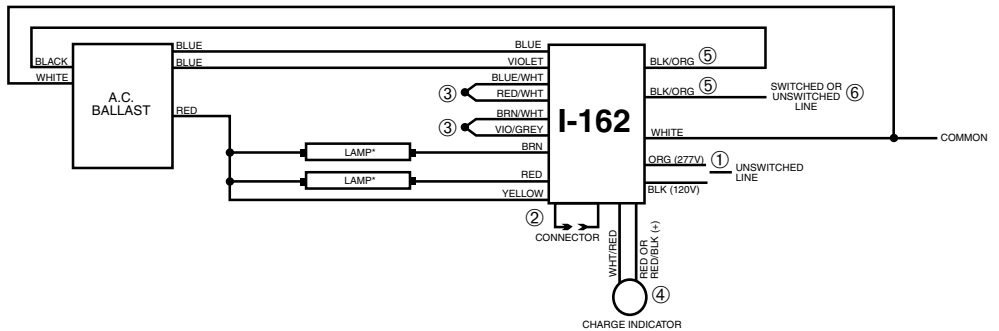

3. TWO LAMP RAPID START BALLAST

* OPERATES IN A.C. AND EMERGENCY MODE.

- ① SELECT PROPER VOLTAGE LEAD. CAP UNUSED LEADS.
- ② DO NOT MATE CONNECTOR UNTIL INSTALLATION IS COMPLETE AND A.C. POWER IS SUPPLIED.
- ③ TEST ACCESSORY LEADS - REFER TO INSTALLATION INSTRUCTIONS FOR PROPER POLARITY LEAD WIRING.
- ④ NO POLARITY ON BLK/ORG LEADS.
- ⑤ SWITCHED OR UNSWITCHED LINE- REFER TO INSTALLATION MANUAL FOR HOT AND TEST SWITCH PLACEMENT.

