



P.O. BOX 11846 TUCSON, AZ 85734  
(520) 294-3292 • FAX (520) 741-2837  
www.iotaengineering.com

# D-48-T

EMERGENCY  
LIGHTING EQUIPMENT

## INSTRUCTION MANUAL

### IMPORTANT SAFEGUARDS

When using electrical equipment, basic safety precautions should always be followed, including the following:

#### READ AND FOLLOW ALL SAFETY INSTRUCTIONS

1. **CAUTION** – To prevent electrical shock, do not mate unit connector until installation is complete and A.C. power is supplied to the unit.
2. **CAUTION** – This fixture provides more than one power supply output source. To reduce the risk of electrical shock, disconnect both normal and 48VDC emergency sources by turning off the A.C. branch circuit, 48VDC system, and by disconnecting the unit connector.
3. **DO NOT USE OUTDOORS.** The **D-48-T** is for use with grounded, UL Listed, indoor fixtures. Not for use in heated air outlets or hazardous locations.
4. The **D-48-T** requires an unswitched A.C. power source of either 120 or 277 volts. Properly cap the unused A.C. lead.
5. Do not mount near gas or electric heaters.
6. The **D-48-T** and A.C. ballast **must** be on the same branch circuit.
7. The **D-48-T** should be mounted in locations and at heights where it will not readily be subjected to tampering by unauthorized personnel.
8. The **D-48-T** will cold strike and operate *one* 2' through 5' instant start, rapid start, U shape or circline, T8 through T12 fluorescent lamps, including energy saving and long 4 pin compacts. The **D-48-T** operates the lamp at full light output.
9. The **D-48-T** is compatible with all A.C. magnetic and electronic ballasts including multiple lamp ballasts with one lamp operating in the emergency mode.
10. The use of accessory equipment not recommended by the manufacturer may cause an unsafe condition, void warranty, and result in non-compliance with UL specifications.
11. Do not use this equipment for other than intended use.
12. Install in accordance with the National Electrical Code and local regulations.
13. Installation and servicing should be performed by qualified personnel.
14. Lighting fixture manufacturers, electricians, and end-users need to ensure product system compatibility before final installation.

SAVE THESE INSTRUCTIONS



# INSTALLATION INSTRUCTIONS

**CAUTION:** Before installing, make certain the A.C. power is off and the D-48-T unit connector is disconnected.

## 1. LAMPS OPERATED

The **D-48-T** can be used with most 2'-5' lamps. If you have any questions regarding specific lamps, contact Customer Service.

## 2. MOUNTING THE D-48-T

Remove the ballast channel cover. Mount the **D-48-T** in the ballast channel at least 1/2" away from the A.C. ballast(s). Note: For proper operation, use only the test accessories provided with the unit. See Page 1 of the *Instruction Manual*.

When the **D-48-T** is remote mounted, consult Customer Service for the maximum allowable distance between the **D-48-T** and the lamp.

## 3. WIRING

Refer to the wiring diagrams on the back page for the appropriate wiring of lamp(s) and ballast. Install in accordance with the National Electrical Code and local regulations. For additional wiring diagrams consult Customer Service.

## 4. WIRING THE D-48-T

- The **D-48-T** and A.C. ballast **must** be on the same branch circuit.
- The **D-48-T** requires an **unswitched** A.C. power source of either 120 or 277 volts. Select the proper voltage lead and cap the unused lead.
- When the **D-48-T** is used with a switched fixture, the A.C. input to the **D-48-T** must be connected ahead of the fixture switch. Refer to *Illustration 1* for switched and unswitched fixture wiring diagrams.

**Illustration 1**

**Switched Fixture**

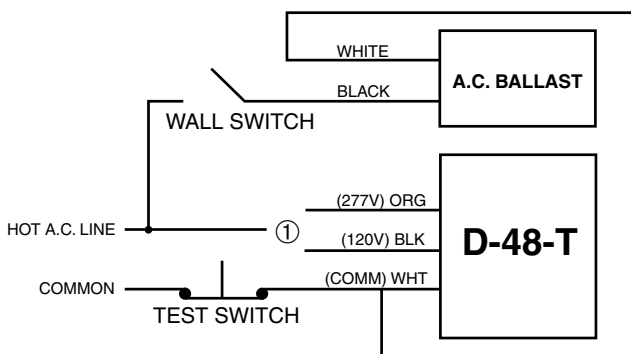

① Select proper voltage lead. Cap unused lead.

**Unswitched Fixture**

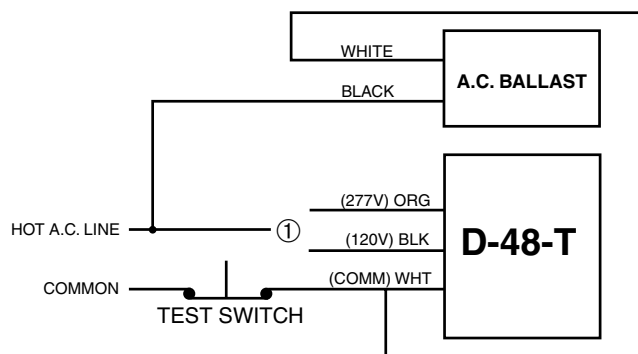

① Select proper voltage lead. Cap unused lead.

## 5. LABELS

Attach the appropriate labels adjacent to the **Test Switch** if required. Annotate Re-lamping label for lamp type and wattage. The Caution and the Re-lamping labels must be on the fixture in a readily visible location to anyone attempting to service the fixture.

## 6. COMPLETING INSTALLATION

When installation is complete, switch the A.C. power on and the 48VDC system power on and join the **D-48-T** unit connector.

# OPERATION

**Normal Mode** – A.C. power is present. The A.C. ballast operates the fluorescent lamp(s) as intended. The **D-48-T** is in the standby mode.

**Emergency Mode** – The A.C. power fails. The **D-48-T** senses the A.C. power failure and automatically switches to the *Emergency Mode*. When the A.C. power is restored, the **D-48-T** switches the system back to the *Standby Mode*. See page 1 of the Instruction Manual.

# TESTING & MAINTENANCE

The **D-48-T** is a maintenance free unit, however, periodic inspection and testing is required, NFPA 101. Life Safety Code, outlines the following schedule.

**Monthly** – Conduct a 30 second discharge test. One lamp should operate at full output.

**Annually** – Conduct a full 1½ hour discharge test. The unit should operate as intended for the duration of the test.

“Written records of testing shall be kept by the owner for inspection by the authority having jurisdiction.”

**SERVICING SHOULD BE PERFORMED BY QUALIFIED PERSONNEL.**  
Consult Customer Service or visit [www.iotaengineering.com](http://www.iotaengineering.com) for current warranty information.

# TYPICAL WIRING DIAGRAMS

For wiring diagrams of ballasts not shown, consult our Customer Service.

Wiring and Troubleshooting Tips are available on-line at <http://www.iotaengineering.com/wiringtips.pdf>

## 1. ONE LAMP RAPID START BALLAST

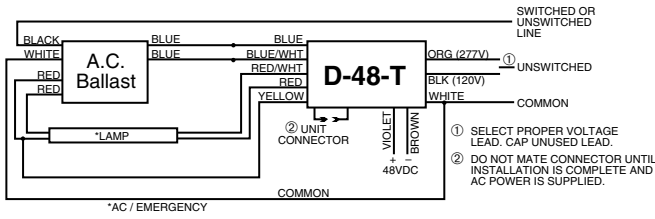

## 6. TWO LAMP INSTANT START BALLAST

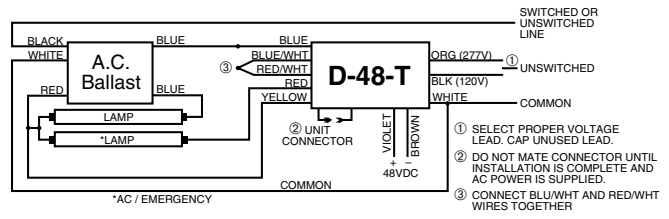

## 2. TWO LAMP RAPID START BALLAST

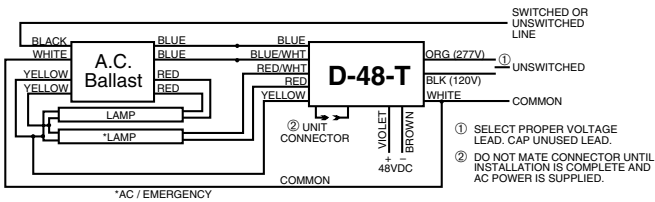

## 7. THREE LAMP INSTANT START BALLAST

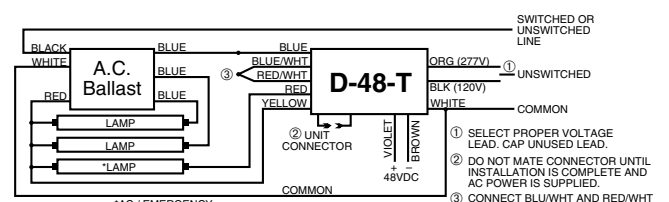

## 3. TWO LAMP RAPID START BALLAST

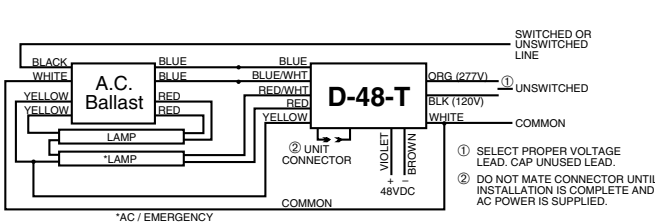

## 8. FOUR LAMP INSTANT START BALLAST

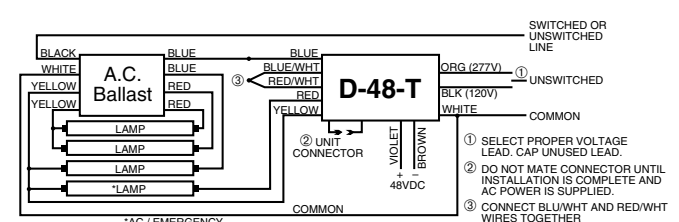

## 4. THREE LAMP RAPID START BALLAST

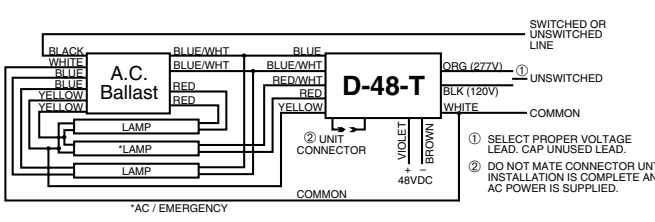

## 9. DC OPERATION ONLY

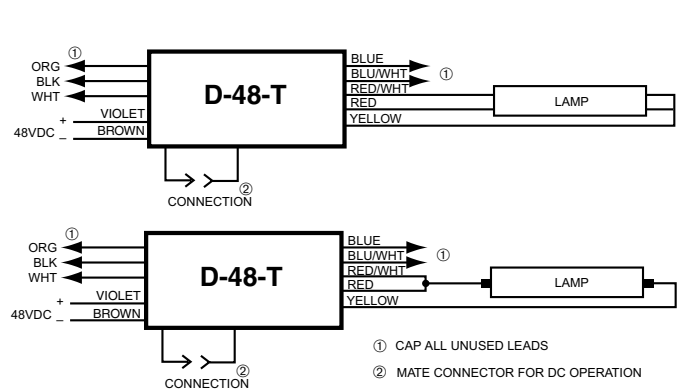

## 5. ONE LAMP INSTANT START BALLAST

