



P.O. BOX 11846 TUCSON, AZ 85734
(520) 294-3292 • FAX (520) 741-2837
www.iotaengineering.com

I-160

SERIES AC
EMERGENCY
LIGHTING EQUIPMENT

INSTRUCTION MANUAL

IMPORTANT SAFEGUARDS

When using electrical equipment, basic safety precautions should always be followed, including the following:

READ AND FOLLOW ALL SAFETY INSTRUCTIONS

1. **CAUTION** – To prevent electrical shock, do not mate unit connector until installation is complete and A.C. power is supplied to the unit.
2. **CAUTION** – This fixture provides more than one power supply output source. To reduce the risk of electrical shock, disconnect both normal and emergency sources by turning off the A.C. branch circuit and by disconnecting the unit connector.
3. **CAUTION** – This is a sealed unit. The integral, high temperature Ni-Cad battery is not replaceable. Replace the entire unit when necessary and recycle or dispose of the nickel-cadmium battery properly.
4. **DO NOT USE OUTDOORS.** The **I-160** is for use with grounded, UL Listed, damp location rated, indoor fixtures. Not for use in heated air outlets or hazardous locations.
5. The **I-160** requires an unswitched A.C. power source of either 120 or 277 volts. Properly cap the unused A.C. lead.
6. When the **I-160** is installed on the same branch circuit, refer to Illustration 3, Figures A and B for input wiring. When installed on separate branch circuits, refer to Illustration 3, Figures C and D for input wiring. Per NEC, the **I-160** and A.C. ballast must be on the same panel board.
7. Do not mount near gas or electric heaters.
8. The **I-160** should be mounted in locations and at heights where it will not readily be subjected to tampering by unauthorized personnel.
9. The **I-160** mounts on top of the fixture or adjacent to the fixture on an optional T-bar mounting bracket.
10. The **I-160** will cold strike and operate *one 2'–4' 24W-95W T5, one 17W-59W T8 lamps, one 25W to 50W long compact, one 18W-70W 4-pin compact lamp, one or two 17W 2' T8 or one or two 18W 4-pin compact fluorescent lamp.*
11. The **I-160** operates lamps as follows:
One or two 2'–4' T8 lamps, or one or two 4-pin compact fluorescent lamps, or one 8' select linear lamp for 90 minutes.
12. Suitable for use in damp locations.
13. For use in 0° C minimum, 50° C maximum ambient temperatures.
14. The use of accessory equipment not recommended by the manufacturer may cause an unsafe condition, void warranty, and result in non-compliance with UL specifications.
15. Do not use this equipment for other than intended use.
16. Install in accordance with the National Electrical Code and local regulations.
17. Installation and servicing should be performed by qualified personnel.
18. Lighting fixture manufacturers, electricians, and end-users need to ensure product system compatibility before final installation.

SAVE THESE INSTRUCTIONS



THIS UNIT CONTAINS A
RECHARGEABLE NICKEL-CADMIUM BATTERY.
PLEASE RECYCLE OR DISPOSE OF PROPERLY.

INSTALLATION INSTRUCTIONS

CAUTION: Before installing, make certain the A.C. power is off and the I-160 unit connector is disconnected.

1. LAMPS OPERATED

The I-160 can be used with most 2'-8' T8, 2'-4' T5, or 4-pin compact lamps. Refer to the chart for the type of lamp(s) operated and the number of lamps to be operated in emergency mode. Contact Customer Service with questions about specific lamps.

*The lamp selector leads each have a 3 position shorting P-nut connector. Select the proper wire combination from the chart for the desired lamp(s) used. Cut and strip one of the selected wires ($\frac{3}{8}$ ") and plug it into the P-nut of the second wire.

OPTION	LAMP TYPE	EMERGENCY OPERATION	*LAMP SELECTOR LEADS		
			Brn/Wht	Brown	Violet
1	17 Watt 2-ft. T8	One Lamp	●	●	
2	17 Watt 2-ft. T8	Two Lamps		●	●
3	32 Watt 4-ft. T8	One Lamp	●	●	
4	59 Watt 8-ft. T8	One Lamp	●		●
5	24W 2-ft. T5	One Lamp	●	●	
6	39W 3-ft. T5	One Lamp	●	●	
7	28W 4-ft. T5	One Lamp	●	●	
8	47W 4-ft. T5	One Lamp	●	●	
9	54W 4-ft. T5	One Lamp		●	●
10	95W 4-ft. T5	One Lamp		●	●
11	95 Watt 8-ft. T12	One Lamp		●	●
12	18W Compact	One Lamp	●	●	
13	18W Compact	Two Lamps		●	●
14	26W Compact	One Lamp	●	●	
15	26W Compact	Two Lamps	●		●
16	32W Compact	One Lamp	●	●	
17	42W Compact	One Lamp		●	●
18	70W Compact	One Lamp	●		●
19	25W Long Compact	One Lamp	●	●	
20	30W Long Compact	One Lamp		●	●
21	50W Long Compact	One Lamp		●	●

2. MOUNTING THE I-160

Remove the ballast channel cover. Mount the I-160 on the fixture top in a position that does not interfere with the existing A.C. ballast or any other hardware. Extend the flex conduit to a convenient location on top of the fixture and punch a $\frac{7}{8}$ " hole. Feed the wires and flex connector down through the hole in the fixture and secure in place with the flex connector nut. An optional T-bar mounting kit is available to mount the I-160 above the ceiling tile adjacent to the emergency fixture. To order the optional T-bar mounting kit (part number TBMK-160) contact Customer Service.

When battery packs are remote mounted, consult Customer Service for the maximum allowable distance between the battery pack and the lamp(s).

CAUTION: Properly secure the I-160 in the ceiling grid to insure compliance with local, state, and federal guidelines regarding ceiling mounted equipment.

3. WIRING

Refer to the wiring diagrams on the back page for the appropriate wiring of lamp(s) and ballast. Install in accordance with the National Electrical Code and local regulations. For additional wiring diagrams consult Customer Service.

4. INSTALLING THE CHARGE INDICATOR

Recessed Troffer Fixture – Select a convenient location with proper clearance in the ballast cover and drill or punch a $\frac{7}{8}$ " hole ($\frac{1}{2}$ " knockout). Insert the $\frac{7}{8}$ " bushing into the hole. Push the plastic tube through the bushing. Disconnect the leads from the LED housing and route the leads down the plastic tube. Reconnect the leads to the housing, observing the proper polarity (Red/Black or Red lead w/connector to positive (+) red tab). Push the entire assembly back into the tube until the lens collar rests against the plastic tube. The plastic tube should be adjusted so that the **Charge Indicator** is within $\frac{1}{4}$ " of the fixture lens. The **Charge Indicator** must be visible after installation. Refer to *Illustration 1*.

Ceiling-Mounted Downlight Fixture – Select a convenient location on the side of the fixture so the **Charge Indicator** can be seen after installation. Allow for proper clearance inside the fixture and drill or punch a $\frac{1}{2}$ " hole. Disconnect the leads from the LED housing. Push the LED housing into the $\frac{1}{2}$ " hole until it is firmly locked in place. Reconnect the leads, observing the proper polarity (Red/Black or Red lead w/connector to positive (+) red tab). Refer to *Illustration 2*. For remote mounting the charge indicator and test switch, the optional RTK accessory kit can be ordered.

Note: For proper operation, use only the accessory components provided with the unit. See Page 1 of the Instruction Manual.

5. INSTALLING THE TEST SWITCH

The **Test Switch** should be mounted on the ballast channel cover of a recessed troffer, or on the side of a strip fixture, preferably adjacent to the charge indicator. Drill or punch a $\frac{1}{2}$ " mounting hole.

Illustration 1 Recessed Troffer Fixture

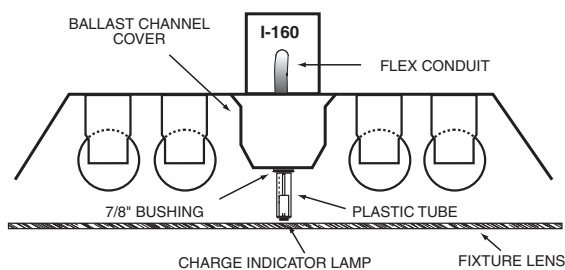

Illustration 2 Downlight Fixture

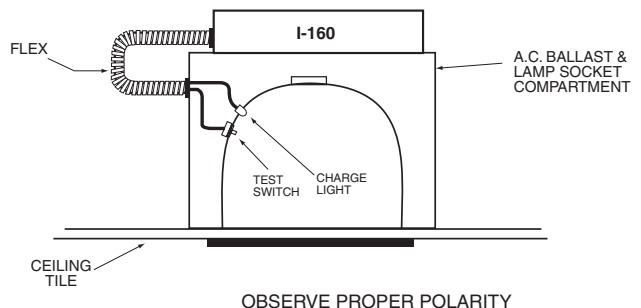
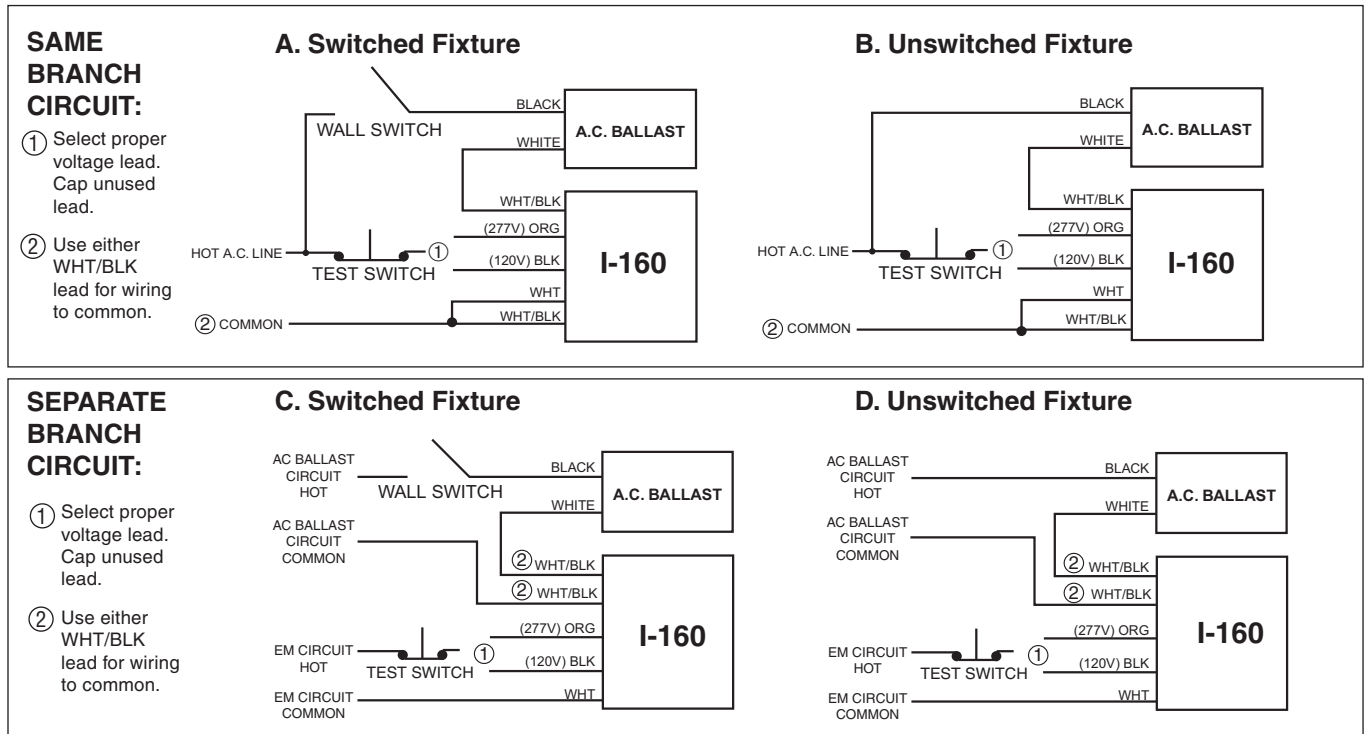

Illustration 3



6. WIRING THE A.C. INPUT

- The **I-160** requires an **unswitched** A.C. power source of either 120 or 277 volts. Select the proper voltage lead and cap the unused lead.
- When the **I-160** is used with a switched fixture, the A.C. input to the **I-160** must be connected ahead of the fixture switch. Refer to *Illustration 3* for switched and unswitched fixture wiring diagrams.
- When installed on separate branch circuits, refer to *Illustration 3*, Figures C and D for input wiring. Per NEC, the **I-160** and A.C. ballast must be on the same panel board.

7. LABELS

Attach the appropriate labels adjacent to the **Test Switch** and **Charge Indicator**. Annotate Re-lamping label for lamp type and wattage. The Caution and the Re-lamping labels must be on the fixture in a readily visible location to anyone attempting to service the fixture.

8. COMPLETING INSTALLATION

When the installation is complete, switch the A.C. power on and join the **I-160** unit connector.

OPERATION

Normal Mode – A.C. power is present. The A.C. ballast operates the fluorescent lamp(s) as intended. The **I-160** is in the standby charging mode. The **Charge Indicator** will be lit providing a visual indication that the battery is being charged.

Emergency Mode – The A.C. power fails. The **I-160** senses the A.C. power failure and automatically switches to the *Emergency Mode*. One or two lamps are illuminated, at reduced output, for a minimum of 90 minutes. When the A.C. power is restored, the **I-160** switches the system back to the *Normal Mode* and resumes battery charging. See page 1 of the Instruction Manual.

TESTING & MAINTENANCE

Initial Testing – Allow the unit to charge approximately 1 hour, then conduct a short discharge test. Allow a 24 hour charge before conducting a one hour test.

The **I-160** is a maintenance free unit, however, periodic inspection and testing is required. NFPA 101, Life Safety Code, outlines the following schedule:

Monthly – Insure that the **Charge Indicator** light is illuminated. Conduct a 30 second discharge test by depressing the **Test Switch**. One lamp or two lamps should operate at full or reduced output, depending on your configuration.

Annually – Insure that the **Charge Indicator** light is illuminated. Conduct a full 1½ hour discharge test. The unit should operate as intended for the duration of the test.

“Written records of testing shall be kept by the owner for inspection by the authority having jurisdiction.”

SERVICING SHOULD BE PERFORMED BY QUALIFIED PERSONNEL.
Consult Customer Service or visit www.iotaengineering.com for current warranty information.

TYPICAL WIRING DIAGRAMS

For wiring diagrams of ballasts not shown, consult our Customer Service.

Wiring and Troubleshooting Tips are available on-line at <http://www.iotaengineering.com/wiringtips.pdf>

1. ONE LAMP RAPID START BALLAST

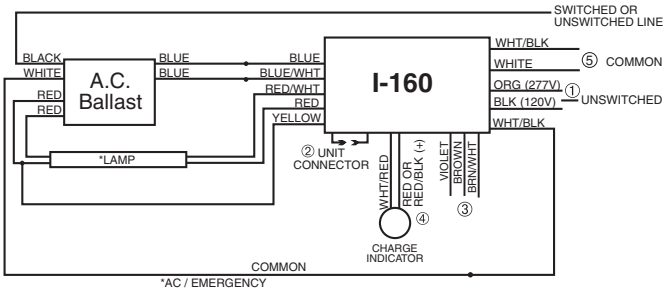

5. ONE LAMP INSTANT START BALLAST

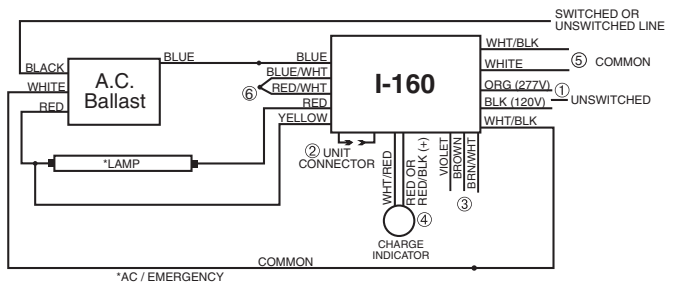

2. TWO LAMP RAPID START BALLAST

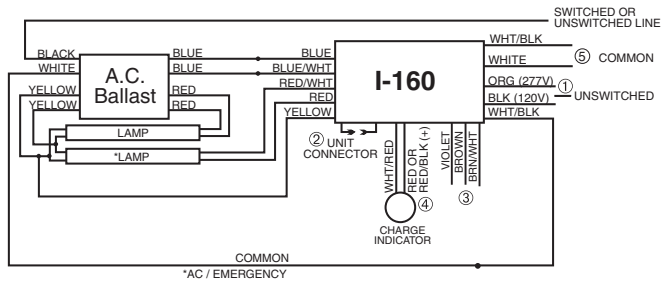

6. TWO LAMP INSTANT START BALLAST

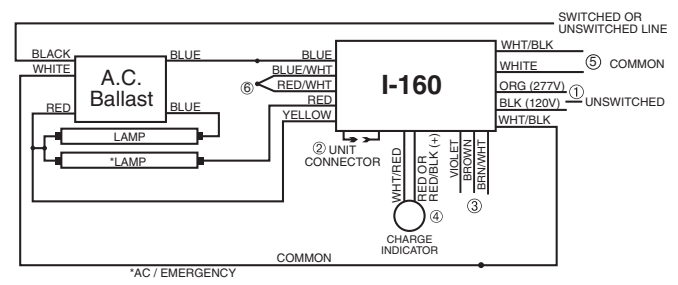

3. TWO LAMP RAPID START BALLAST

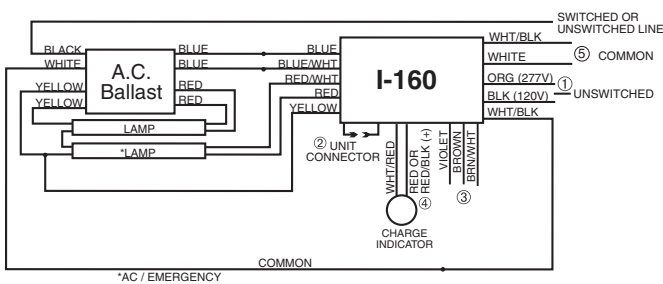

7. THREE LAMP INSTANT START BALLAST

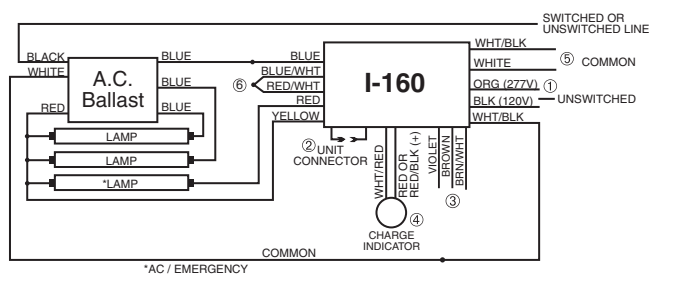

4. THREE LAMP RAPID START BALLAST

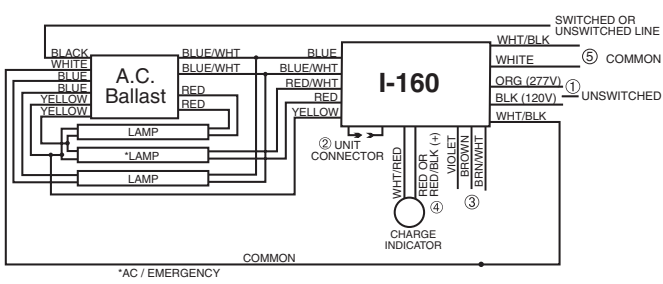

8. FOUR LAMP INSTANT START BALLAST

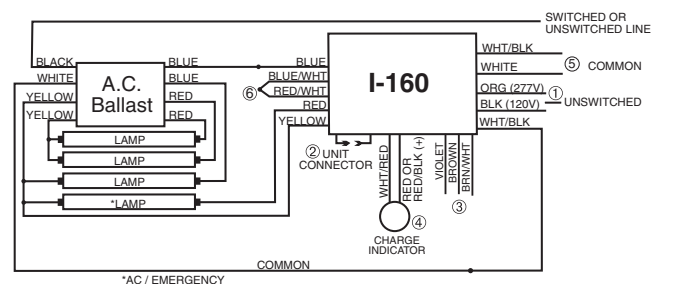

9. TWO LAMP RAPID START BALLAST W/2 LAMP EMERGENCY OPERATION

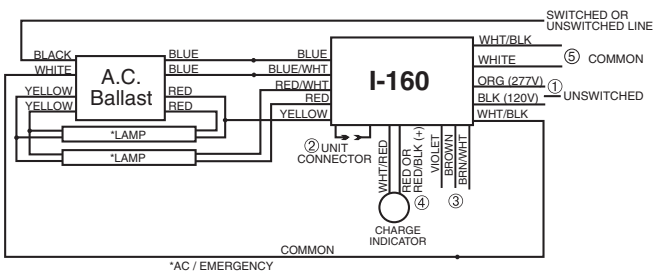

10. TWO LAMP INSTANT START BALLAST W/2 LAMP EMERGENCY OPERATION

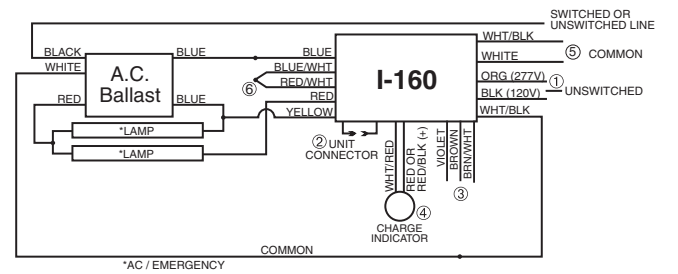

① SELECT PROPER VOLTAGE LEAD. CAP UNUSED LEAD. REFER TO AC INPUT WIRING ON ILLUSTRATION 3 OF INSTALLATION MANUAL FOR PROPER INPUT CIRCUIT WIRING.

② DO NOT MATE CONNECTOR UNTIL INSTALLATION IS COMPLETE AND AC POWER IS SUPPLIED.

③ LAMP SELECTOR LEADS—REFER TO INSTALLATION INSTRUCTIONS, LAMPS OPERATION SECTION FOR VARIOUS OPTIONS

④ TEST ACCESSORY LEADS—REFER TO INSTALLATION INSTRUCTIONS FOR PROPER POLARITY WIRING.

⑤ USE EITHER WHT/BLK LEAD FOR WIRING THE COMMON. REFER TO AC INPUT WIRING ON ILLUSTRATION 3 OF INSTALLATION MANUAL.

⑥ CONNECT BLU/WHT AND RED/WHT WIRES TOGETHER

TYPICAL WIRING DIAGRAMS

For wiring diagrams of ballasts not shown, consult our Customer Service.

Wiring and Troubleshooting Tips are available on-line at <http://www.iotaengineering.com/wiringtips.pdf>

11. ONE LAMP RAPID START BALLAST

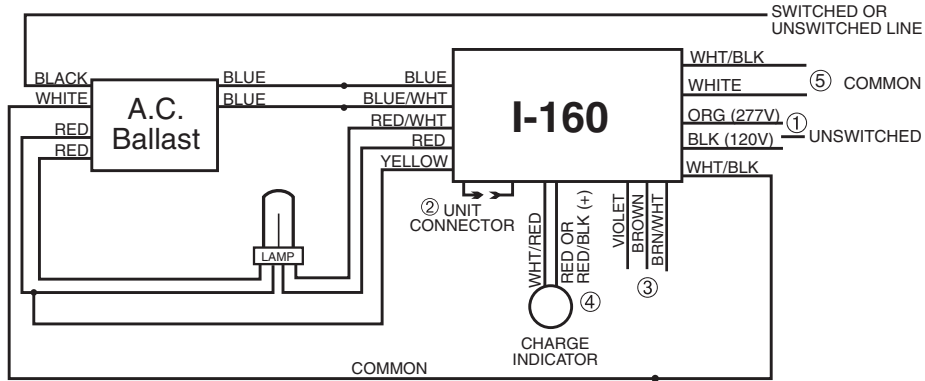

12. TWO LAMP RAPID START BALLAST

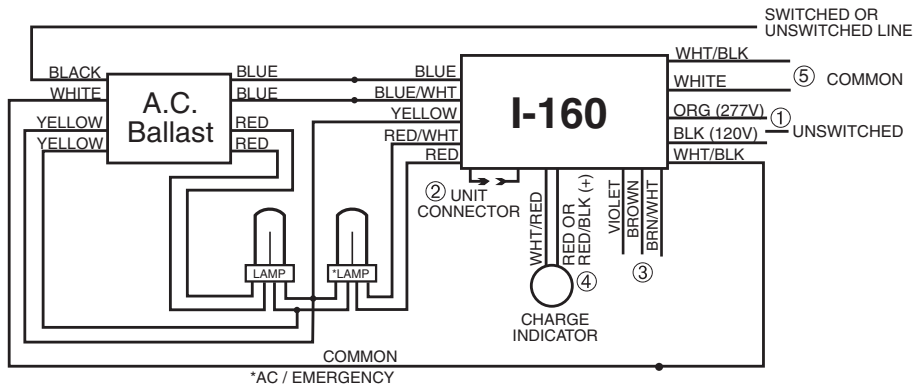

13. TWO LAMP RAPID START BALLAST WITH TWO LAMP OPERATION

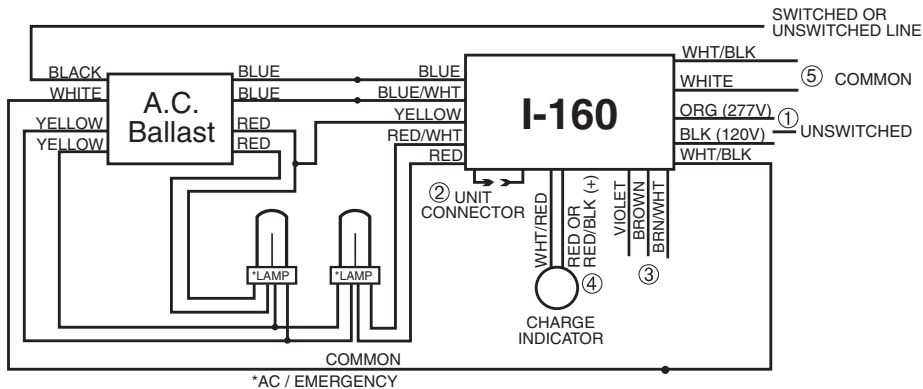

① SELECT PROPER VOLTAGE LEAD. CAP UNUSED LEAD. REFER TO AC INPUT WIRING ON ILLUSTRATION 3 OF INSTALLATION MANUAL FOR PROPER INPUT CIRCUIT WIRING.

② DO NOT MATE CONNECTOR UNTIL INSTALLATION IS COMPLETE AND AC POWER IS SUPPLIED.

③ LAMP SELECTOR LEADS—REFER TO INSTALLATION INSTRUCTIONS, LAMPS OPERATION SECTION FOR VARIOUS OPTIONS

④ TEST ACCESSORY LEADS—REFER TO INSTALLATION INSTRUCTIONS FOR PROPER POLARITY WIRING.

⑤ USE EITHER WHT/BLK LEAD FOR WIRING THE COMMON. REFER TO AC INPUT WIRING ON ILLUSTRATION 3 OF INSTALLATION MANUAL.

⑥ CONNECT BLU/WHT AND RED/WHT WIRES TOGETHER