

## INSTRUCTION MANUAL

### IMPORTANT SAFEGUARDS

When using electrical equipment, basic safety precautions should always be followed, including the following:

#### READ AND FOLLOW ALL SAFETY INSTRUCTIONS

1. **CAUTION** – To prevent electrical shock, do not mate unit connector until installation is complete and A.C. power is supplied to the unit.
2. **CAUTION** – This fixture provides more than one power supply output source. To reduce the risk of electrical shock, disconnect both normal and emergency sources by turning off the A.C. branch circuit and by disconnecting the unit connector.
3. **CAUTION** – The integral, high temperature Ni-Cad battery is replaceable. To replace the battery, disconnect the unit connector and remove both switched and unswitched A.C. power to the fixture. Remove the lid screw and open the lid to expose the battery. Unplug the battery connector and replace with part number 44203-412 (14.4V Ni-Cad battery only). Recycle or dispose of the used nickel-cadmium battery properly.
4. **DO NOT USE OUTDOORS.** The **I-160** is for use with grounded, UL Listed, indoor fixtures except in heated air outlets or hazardous locations.
5. The **I-160** requires an unswitched A.C. power source of either 120 or 277 volts. Properly cap the unused A.C. lead.
6. Do not mount near gas or electric heaters.
7. The **I-160** should be mounted in locations and at heights where it will not readily be subjected to tampering by unauthorized personnel.
8. The **I-160** mounts on top of the fixture or adjacent to the fixture on an optional T-bar mounting bracket.
9. The **I-160** will cold strike and operate *one* 2'-4' 28W-54W T5, one 2'-8', or one or two 2'-4' instant start, rapid start, U shape or circline, T8 through T12 fluorescent lamps, including energy saving and long 4 pin compact lamps for 90 minutes.
10. The **I-160** operates lamps as follows:
  - One 2'-8', or two 2'-4' T8 through T12 lamps for 90 minutes at reduced light output.
  - One 2'-4' T5 lamp for 90 minutes at full light output.
11. The use of accessory equipment not recommended by the manufacturer may cause an unsafe condition.
12. Do not use this equipment for other than intended use.
13. Install in accordance with the National Electrical Code and local regulations.
14. Installation and servicing should be performed by qualified personnel.
15. Lighting fixture manufacturers, electricians, and end-users need to ensure product system compatibility before final installation.

SAVE THESE INSTRUCTIONS



THIS UNIT CONTAINS A  
RECHARGEABLE NICKEL-  
CADMIUM BATTERY. PLEASE  
RECYCLE OR DISPOSE OF  
PROPERLY.

Ni-Cd

# INSTALLATION INSTRUCTIONS

**CAUTION:** Before installing, make certain the A.C. power is off and the I-160 unit connector is disconnected.

## 1. LAMPS OPERATED

The I-160 can be used with most 2'–8' lamps. Refer to the chart below for the type of lamp(s) operated and the number of lamps to be operated in emergency mode. Contact Customer Service with questions about specific lamps.

OPTION	LAMP TYPE	EMERGENCY OPERATION	*LAMP SELECTOR LEADS		
			Brn/Wht	Brown	Violet
1	2-4 T-8/T-12, Circline	One Lamp	X	X	
2	2-4 T-8/T-12, Circline	Two Lamp		X	X
3	8 T-12	One Lamp	X		X
4	28W, 54W T5	One Lamp	X	X	
5	10W-42W 4-Pin Compact	One Lamp	X	X	
6	10W-26W 4-Pin Compact	Two Lamp	X	X	
7	32W-42W 4-Pin Compact	Two Lamp	X		X
8	57W, 70W 4-Pin Compact	One Lamp	X		X
9	40W-50W Long Compact	One Lamp	X	X	
10	40W Long Compact	Two Lamp		X	X
11	55W Long Compact	One Lamp	X		X

\*The lamp programming wires each have a 3 position shorting P-nut connector. Select the proper wire combination from the chart above for the desired lamp(s) used. Cut and strip one of the selected wires ( $\frac{3}{8}$ " ) and plug it into the P-nut of the second wire.

## 2. MOUNTING THE I-160

Remove the ballast channel cover. Mount the I-160 on the fixture top in a position that does not interfere with the existing A.C. ballast or any other hardware. Extend the flex conduit to a convenient location on top of the fixture and punch a  $\frac{7}{8}$ " hole. Feed the wires and flex connector down through the hole in the fixture and secure in place with the flex connector nut. An optional T-bar mounting kit is available to mount the I-160 above the ceiling tile adjacent to the emergency fixture. To order the optional T-bar mounting kit (part number TBMK-160) contact Customer Service.

When battery packs are remote mounted, the remote distance can not exceed  $\frac{1}{2}$  of the distance from ballast to lamp specified by the A.C. ballast manufacturer. For example, if the A.C. ballast manufacturer recommends no more than 25' remote distance, then the battery pack should not exceed  $12\frac{1}{2}$ '. Under no circumstances should the battery pack exceed a distance of 50' from the lamp.

**CAUTION:** Properly secure the I-160 in the ceiling grid to insure compliance with local, state, and federal guidelines regarding ceiling mounted equipment.

## 3. WIRING

Refer to the wiring diagrams on the back page for the appropriate wiring of lamp(s) and ballast. Install in accordance with the National Electrical Code and local regulations. For additional wiring diagrams consult Customer Service.

## 4. INSTALLING THE CHARGE INDICATOR

*Recessed Troffer Fixture* – Select a convenient location with proper clearance in the ballast cover and drill or punch a  $\frac{7}{8}$ " hole ( $\frac{1}{2}$ " knockout). Insert the  $\frac{7}{8}$ " bushing into the hole. Push the plastic tube through the bushing. Disconnect the leads from the LED housing and route the leads down the plastic tube. Reconnect the leads to the housing, observing the proper polarity (Red/Black or Red lead w/connector to positive (+) red tab). Push the entire assembly back into the tube until the lens collar rests against the plastic tube. The plastic tube should be adjusted so that the **Charge Indicator** is within  $\frac{1}{4}$ " of the fixture lens. The **Charge Indicator** must be visible after installation. Refer to *Illustration 1*.

*Strip Fixture* – Select a convenient location on the side of the fixture so the **Charge Indicator** can be seen after installation. Allow for proper clearance inside the fixture and drill or punch a  $\frac{1}{2}$ " hole. Disconnect the leads from the LED housing. Push the LED housing into the  $\frac{1}{2}$ " hole until it is firmly locked in place. Reconnect the leads, observing the proper polarity (Red/Black or Red lead w/connector to positive (+) red tab). Refer to *Illustration 2*.

**Illustration 1 Recessed Troffer Fixture**

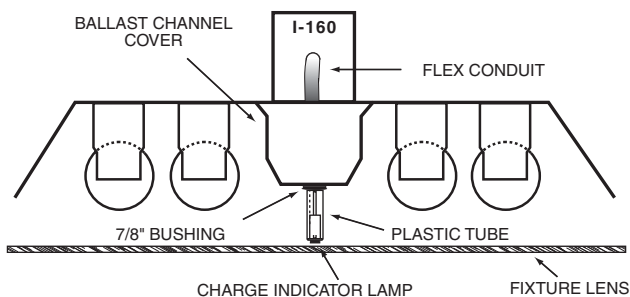

**Illustration 2 Strip Fixture**

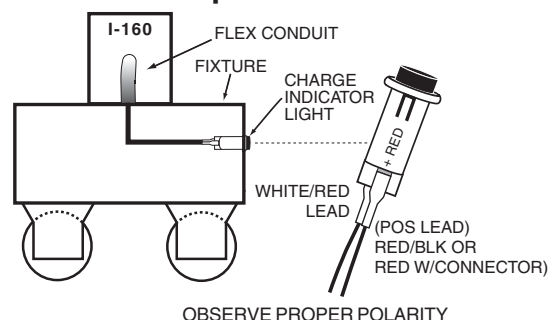

## 5. INSTALLING THE TEST SWITCH

The **Test Switch** should be mounted on the ballast channel cover of a recessed troffer, or on the side of a strip fixture, preferably adjacent to the charge indicator. Drill or punch a 1/2" mounting hole.

## 6. WIRING THE A.C. INPUT

- The **I-160** and A.C. ballast **must** be on the same branch circuit.
- The **I-160** requires an **unswitched** A.C. power source of either 120 or 277 volts. Select the proper voltage lead and cap the unused lead.
- When the **I-160** is used with a switched fixture, the A.C. input to the **I-160** must be connected ahead of the fixture switch. Refer to *Illustration 3* for switched and unswitched fixture wiring diagrams.

## 7. LABELS

Attach the appropriate labels adjacent to the **Test Switch** and **Charge Indicator**. Annotate Re-lamping label for lamp type and wattage. The Caution and the Re-lamping labels must be on the fixture in a readily visible location to anyone attempting to service the fixture.

Illustration 3

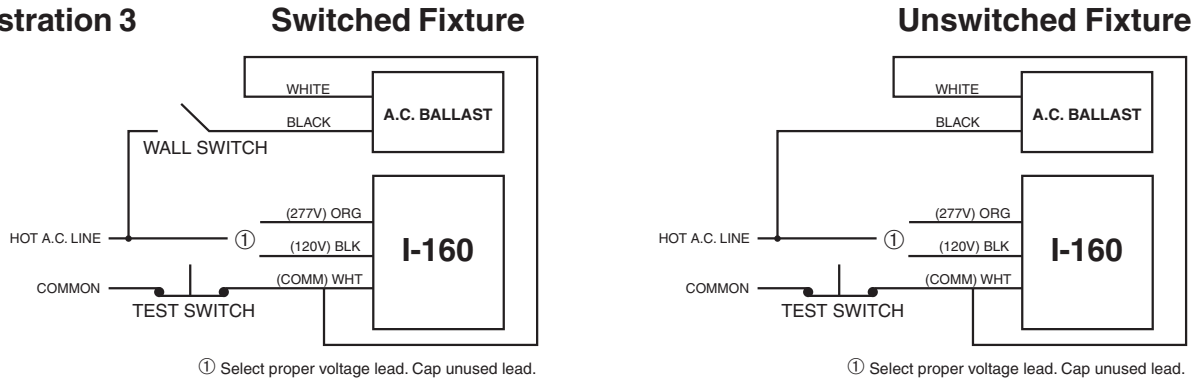

## 8. COMPLETING INSTALLATION

When the installation is complete, switch the A.C. power on and join the **I-160** unit connector.

# OPERATION

**Normal Mode** – A.C. power is present. The A.C. ballast operates the fluorescent lamp(s) as intended. The **I-160** is in the standby charging mode. The **Charge Indicator** will be lit providing a visual indication that the battery is being charged.

**Emergency Mode** – The A.C. power fails. The **I-160** senses the A.C. power failure and automatically switches to the *Emergency Mode*. One or two lamps are illuminated, at reduced output, for a minimum of 90 minutes. When the A.C. power is restored, the **I-160** switches the system back to the *Normal Mode* and resumes battery charging. See page 1 of the Instruction Manual.

# TESTING & MAINTENANCE

**Initial Testing** – Allow the unit to charge approximately 1 hour, then conduct a short discharge test. Allow a 24 hour charge before conducting a one hour test.

The **I-160** is a maintenance free unit, however, periodic inspection and testing is required. NFPA 101, Life Safety Code, outlines the following schedule:

**Monthly** – Insure that the **Charge Indicator** light is illuminated. Conduct a 30 second discharge test by depressing the **Test Switch**. One lamp or two lamps should operate at full or reduced output, depending on your configuration.

**Annually** – Insure that the **Charge Indicator** light is illuminated. Conduct a full 1 1/2 hour discharge test. The unit should operate as intended for the duration of the test.

"Written records of testing shall be kept by the owner for inspection by the authority having jurisdiction."

**SERVICING SHOULD BE PERFORMED BY QUALIFIED PERSONNEL.**  
Consult Customer Service or visit [www.iotaengineering.com](http://www.iotaengineering.com) for current warranty information.

# TYPICAL WIRING DIAGRAMS

For wiring diagrams of ballasts not shown, consult our Customer Service.

## 1. ONE LAMP RAPID START BALLAST

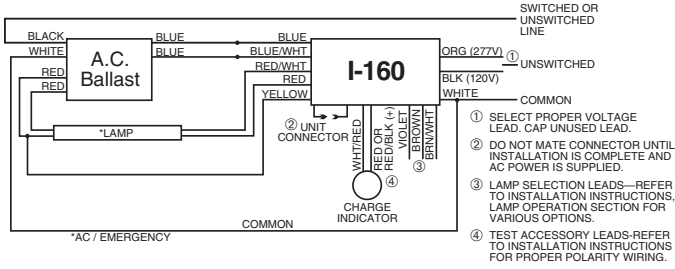

## 5. ONE LAMP INSTANT START BALLAST

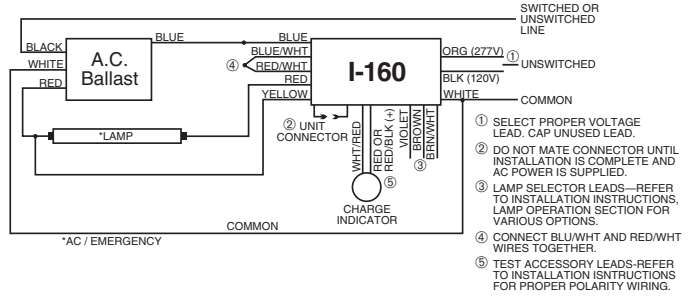

## 2. TWO LAMP RAPID START BALLAST

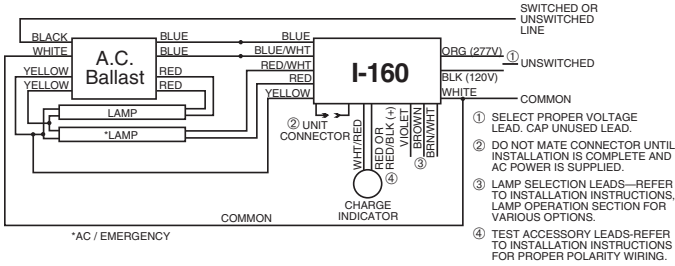

## 6. TWO LAMP INSTANT START BALLAST

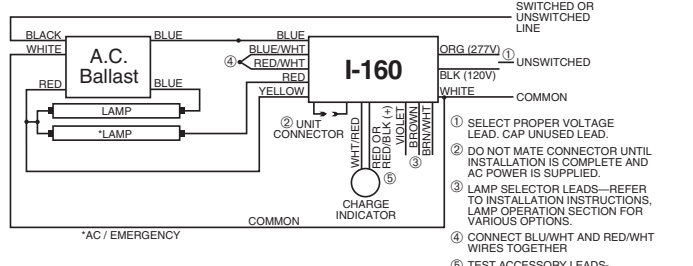

## 3. TWO LAMP RAPID START BALLAST

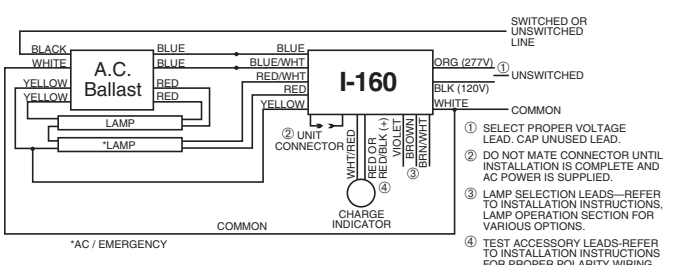

## 7. THREE LAMP INSTANT START BALLAST

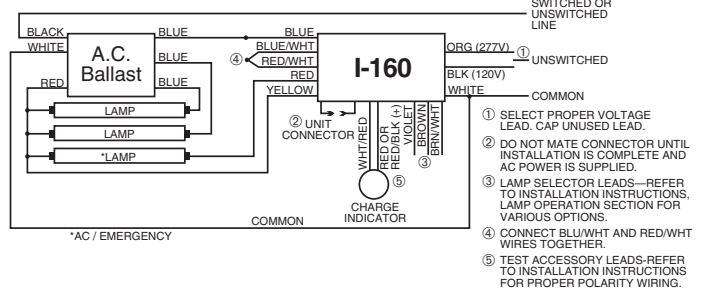

## 4. THREE LAMP RAPID START BALLAST

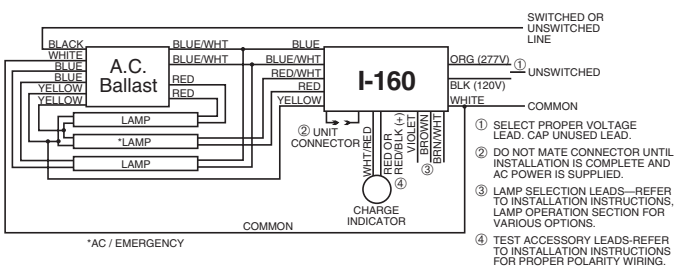

## 8. FOUR LAMP INSTANT START BALLAST

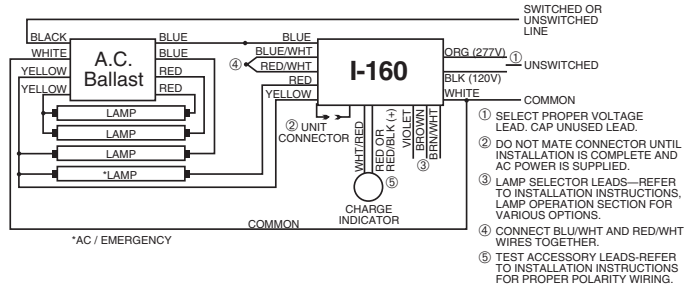

## 9. TWO LAMP RAPID START BALLAST W/2 LAMP EMERGENCY OPERATION

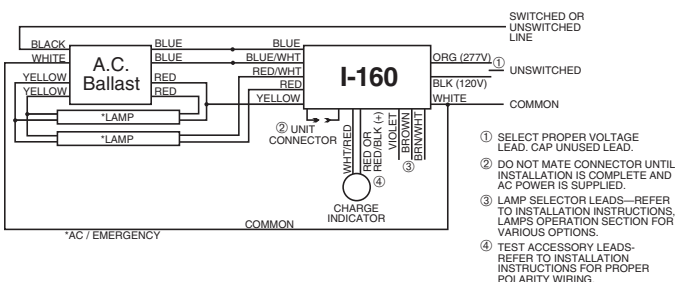

## 10. TWO LAMP INSTANT START BALLAST W/2 LAMP EMERGENCY OPERATION

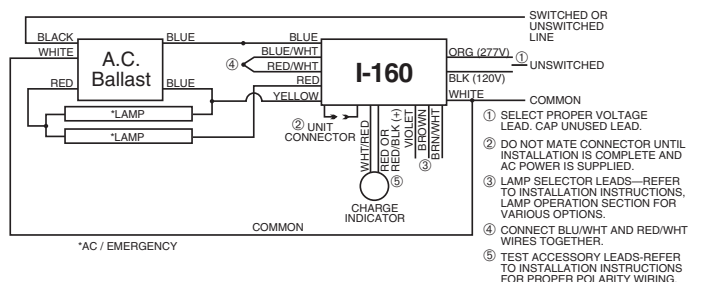

# ADDITIONAL WIRING DIAGRAMS

For wiring diagrams of ballasts not shown, consult our Customer Service.

## 1. THREE LAMP RAPID START BALLAST

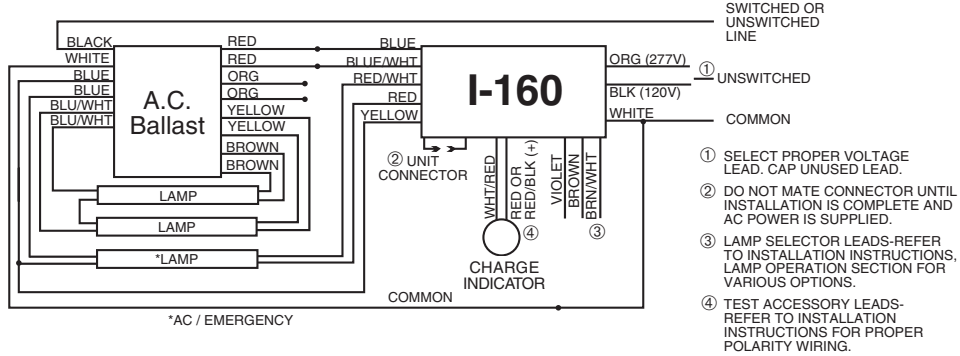

## 2. FOUR LAMP RAPID START BALLAST

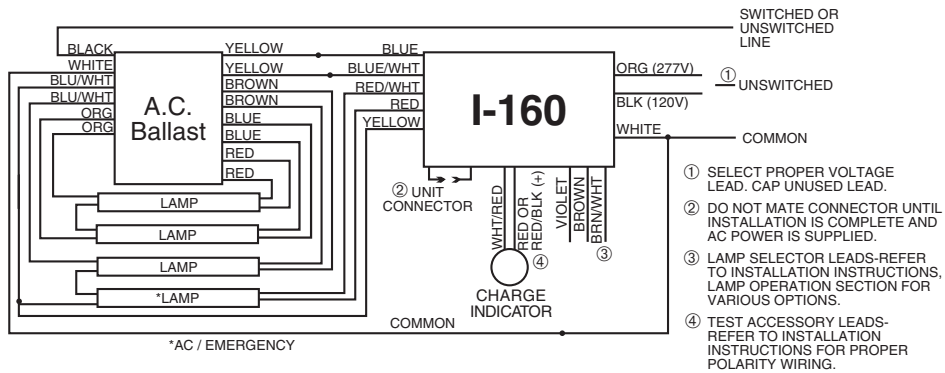

## 3. FOUR LAMP RAPID START BALLAST

