

P.O. BOX 11846 TUCSON, AZ 85734
(520) 294-3292 • FAX (520) 741-2837
www.iotaengineering.com

ISD-420-EM-A

UNIVERSAL VOLTAGE
EMERGENCY
LIGHTING EQUIPMENT

INSTRUCTION MANUAL

IMPORTANT SAFEGUARDS

When using electrical equipment, basic safety precautions should always be followed, including the following:

READ AND FOLLOW ALL SAFETY INSTRUCTIONS

1. **CAUTION** – To prevent electrical shock, do not mate unit connector until installation is complete and A.C. power is supplied to the unit.
2. **CAUTION** – This fixture provides more than one power supply output source. To reduce the risk of electrical shock, disconnect both normal and emergency sources by turning off the A.C. branch circuit and by disconnecting the unit connector.
3. **CAUTION** – This is a sealed unit. The integral, high temperature Ni-Cad battery is not replaceable. Replace the entire unit when necessary and recycle or dispose of the nickel-cadmium battery properly.
4. **DO NOT USE OUTDOORS.** The **ISD-420-EM-A** is for use with grounded, UL Listed, indoor fixtures. Not for use in heated air outlets or hazardous locations.
5. The **ISD-420-EM-A** requires an unswitched A.C. power source of 110-277V 50/60HZ.
6. Do not mount near gas or electric heaters.
7. The **ISD-420-EM-A** should be mounted in locations and at heights where it will not readily be subjected to tampering by unauthorized personnel.
8. The **ISD-420-EM-A** will cold strike and operate *one* 10W through 70W, or *two* 10W through 32W, 4 pin Rapid Start compact fluorescent lamps. Contact Customer Service for additional lamp usage.
9. The **ISD-420-EM-A** is compatible with most electronic A.C. ballasts (including multiple lamps) as follows:
Electronic ballasts – one or two lamp emergency operation.
10. The use of accessory equipment not recommended by the manufacturer may cause an unsafe condition.
11. Do not use this equipment for other than intended use.
12. Install in accordance with the National Electrical Code and local regulations.
13. Installation and servicing should be performed by qualified personnel.
14. Lighting fixture manufacturers, electricians, and end-users need to ensure product system compatibility before final installation.

SAVE THESE INSTRUCTIONS



THIS UNIT CONTAINS A
RECHARGEABLE NICKEL-
CADMIUM BATTERY. PLEASE
RECYCLE OR DISPOSE OF
PROPERLY.

INSTALLATION INSTRUCTIONS

CAUTION: Before installing, make certain the A.C. power is off and the ISD-420-EM-A unit connector is disconnected.

1. LAMPS OPERATED

Refer to the chart below for the type of lamp(s) operated and the number of lamps to be operated in the emergency mode.

If you have any questions regarding specific lamps, contact Customer Service.

| OPTION | LAMP | TYPE | EMERGENCY OPERATION | *VIOLET LEADS | WIRING DIAGRAMS |
|--------|---------|---------|---------------------|---------------|-----------------|
| 1 | 10W-32W | Compact | One Lamp | Connected | 1,2 |
| 2 | 42W-70W | Compact | One Lamp | Disconnected | 1,2 |
| 3 | 10W-13W | Compact | Two Lamp | Connected | 3 |
| 4 | 18W-32W | Compact | Two Lamp | Disconnected | 3 |

*The 6" violet leads provide the lamp selection option. The unit is shipped from the factory with the leads disconnected and capped. When used with particular lamp types, violet leads should be connected to one another. Refer to chart for lamp selection options.

2. MOUNTING THE ISD-420-EM-A

When used with ceiling mounted downlight fixtures, the **ISD-420-EM-A** should be mounted on the fixture above the ceiling. The flex conduit marked "A" should be wired into the ballast/lamp compartment or to an electrical junction box on the fixture which allows access to the ballast/lamp connections. Refer to *Illustration 1* for typical mounting.

When battery packs are remote mounted, the remote distance can not exceed 1/2 of the distance from ballast to lamp specified by the A.C. ballast manufacturer. Under no circumstances should the battery back exceed a distance of 50' from the lamp.

3. WIRING

Refer to the wiring diagrams on the back page for the appropriate wiring of lamp(s) and ballast. Install in accordance with the National Electrical Code and local regulations. For additional wiring diagrams consult Customer Service.

4. INSTALLING THE LIGHTED PUSH BUTTON TEST SWITCH (LPTS)

Cut a single gang switch box into the ceiling tile adjacent to the fixture within reach of the **ISD-420-EM-A** flex. After mounting the switch box, connect flex to the box and route all leads inside the box. The positive terminal will be indicated by the red mark on the side of the LPTS switch.

5. WIRING THE A.C. INPUT

- A. The **ISD-420-EM-A** and A.C. ballast **must** be on the same branch circuit.
- B. The **ISD-420-EM-A** requires an **unswitched** A.C. power source of 110-277V 50/60HZ.
- C. When the **ISD-420-EM-A** is used with a switched fixture, the A.C. input to the **ISD-420-EM-A** must be connected ahead of the fixture switch. Refer to *Illustration 2* for switched and unswitched fixture wiring diagrams.

Illustration 1

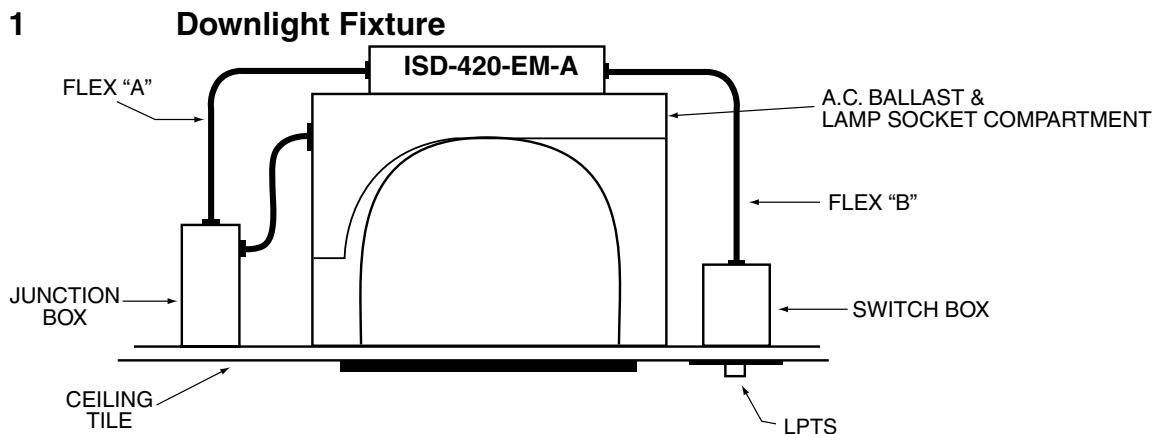

INSURE WIRING IS IN ACCORDANCE WITH THE NATIONAL ELECTRICAL CODE AND LOCAL REGULATIONS.

Illustration 2

Switched Fixture

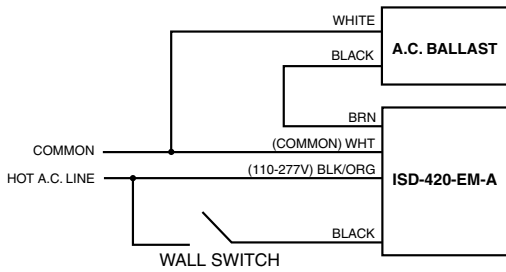

Unswitched Fixture

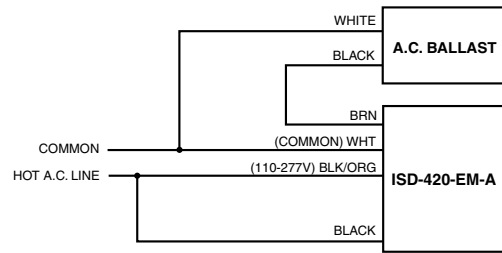

6. LABELS

Attach the appropriate labels adjacent to the **LPTS**. Annotate Re-lamping label for lamp type and wattage. The Caution and the Re-lamping labels must be on the fixture in a readily visible location to anyone attempting to service the fixture.

7. COMPLETING INSTALLATION

When the installation is complete, switch the A.C. power on and join the **ISD-420-EM-A** unit connector.

OPERATION

Normal Mode – A.C. power is present. The A.C. ballast operates the fluorescent lamp(s) as intended. The **ISD-420-EM-A** is in the standby charging mode. The **LPTS** will be lit (green) providing a visual indication that the battery is fully charged and (red) when battery is currently being charged.

Emergency Mode – The A.C. power fails. The **ISD-420-EM-A** senses the A.C. power failure and automatically switches to the *Emergency Mode*. One lamp or two lamps are illuminated, at reduced output, for a minimum of 90 minutes. When the A.C. power is restored, the **ISD-420-EM-A** switches the system back to the *Normal Mode* and resumes battery charging. See page 1 of the Instruction Manual.

TESTING & MAINTENANCE

Pressing and releasing the **LPTS** initiates a 30-second test by interrupting power to the designated A.C. ballast and causing the unit to run in emergency mode. The designated emergency lamp is now being lit by the **ISD-420-EM-A** unit for a 30-second test. After the 30-second test has completed, the fixture returns to normal operation. To simulate a “BLACK OUT” use the circuit breaker to turn off A.C. power to the fixture.

Initial Testing – Allow the unit to charge approximately 1 hour, then conduct a short discharge test. Allow a 72 hour charge before conducting a one hour test.

The **ISD-420-EM-A** is designed to automatically conduct both 30-second and 90-minute tests at regular intervals every 26 to 28 days. Automatic Testing is outlined in the following schedule:

Automatic Monthly Testing – The **ISD-420-EM-A** will automatically conduct a 30 second test once. If the **ISD-420-EM-A** encounters a problem, the **LPTS** will flash and the internal beeper will sound. See Table below for diagnosis.

Automatic Annual Testing – The **ISD-420-EM-A** will automatically conduct a 90 minute test every twelve months. If the **ISD-420-EM-A** encounters a problem, the **LPTS** will flash and the internal beeper will sound. See Table below for diagnosis.

To insure accurate testing, the **ISD-420-EM-A** will not conduct any scheduled automatic tests for a period of 72 hours after the unit has discharged, regardless of reason, for more than five minutes.

Manual Testing - Manual Testing can be performed on the **ISD-420-EM-A** at any time, provided the unit is fully charged, by pressing and releasing the **LPTS** (see above). Manual Testing will not interfere with the automatic testing schedule of the **ISD-420-EM-A** and will display the same diagnosis indicators as automatic testing.

| LED IS RED WHEN CHARGING, GREEN WHEN READY | | | FAILURE CODES OCCUR ONCE EVERY 15 SECONDS WITH 1 SECOND DELAY BETWEEN CODES IN INSTANCES OF MULTIPLE FAILURE |
|--|---------|-----------|--|
| CHARGE FAILURE | 1 BEEP | 1 FLASH | |
| BATTERY FAILURE | 2 BEEPS | 2 FLASHES | |
| LAMP FAILURE* | 3 BEEPS | 3 FLASHES | |
| INVERTER FAILURE* | 4 BEEPS | 4 FLASHES | |

*IF FAILURE, REPLACE LAMP AND RETEST

SERVICING SHOULD BE PERFORMED BY QUALIFIED PERSONNEL.
 Consult Customer Service or visit www.iotaengineering.com for current warranty information.

TYPICAL WIRING DIAGRAMS

Use in conjunction with Rapid Start ballasts and 4 pin lamps only

1. ONE LAMP RAPID START BALLAST

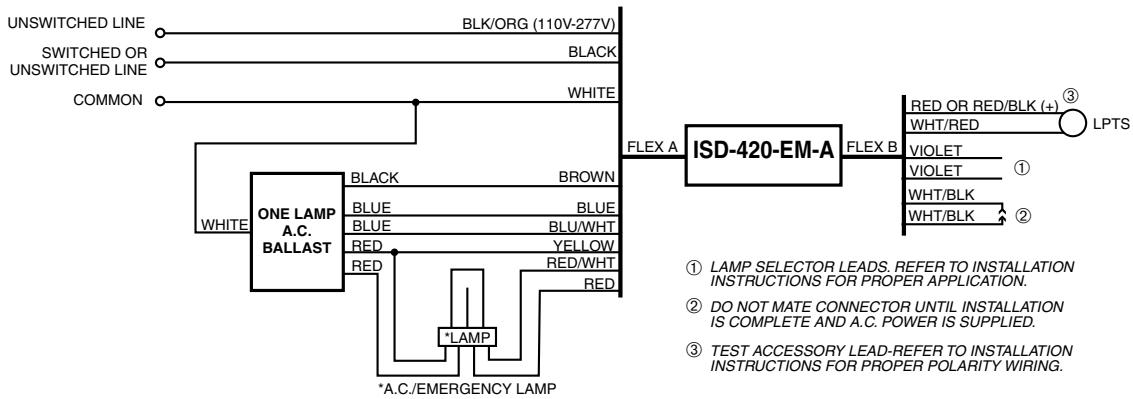

2. TWO LAMP RAPID START BALLAST WITH ONE LAMP EMERGENCY OPERATION

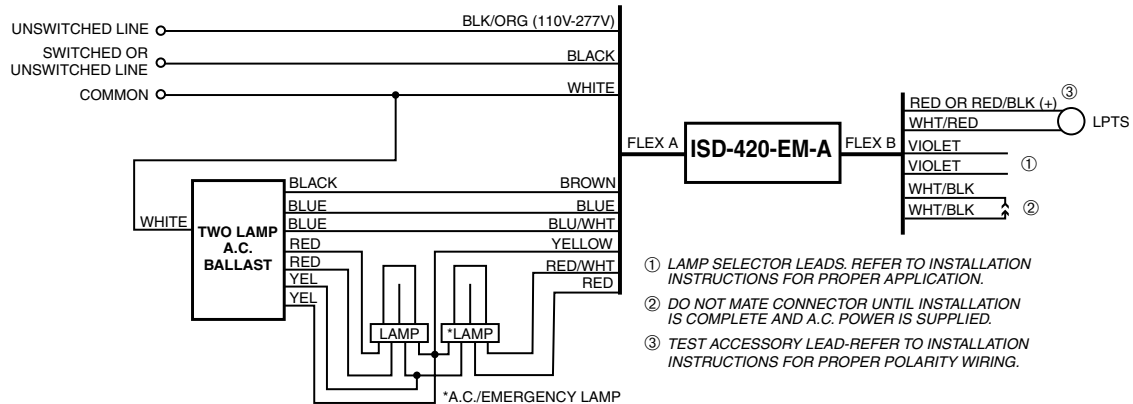

3. TWO LAMP RAPID START BALLAST WITH TWO LAMP EMERGENCY OPERATION

