



MODEL NO: \_\_\_\_\_  
 TYPE: \_\_\_\_\_  
 PROJECT: \_\_\_\_\_  
 COMMENTS: \_\_\_\_\_

**INITIAL LUMEN OUTPUT**  
 650 Lumens

**LAMPS OPERATED\***



(1) 7,9, or 13 Watt Twin Tube **2-PIN** with integral starter  
 (1) 9W-13W USA Quad **2-PIN** with integral starter

\*Refer to Lumen Reference Chart for list of compatible lamps

## DESCRIPTION

The **I-13-EM-B** from IOTA Engineering is a UL Listed fluorescent emergency ballast that allows the same fixture to be used for both normal and emergency operation. In the event of a power failure, the **I-13-EM-B** switches to the emergency mode and operates **one** of the existing lamps for **90 minutes**. The unit contains a battery, charger, and inverter circuit in a single can. The **I-13-EM-B** can be used with most 7, 9, & 13 watt **2-pin** twin tube compact fluorescent lamps, with an initial output of up to **650 lumens** for one lamp. The **I-13-EM-B** features an integral can profile for installation directly within the ballast compartment and is suitable for use in damp locations and enclosed and gasketed fixtures.

## SPECIFICATIONS

Input Voltage .....	(Dual) 120/277V, 60Hz
Input Wattage .....	3.5 Watts
Lamps Operated .....	7,9 & 13 Watt Twin Tube 2-PIN with integral starter 9W-13W USA quad 2-PIN with integral starter
Emergency Operation .....	90 minutes
Initial Illumination .....	(1) lamp 650 lumens
Operating Temp .....	0° to 50° C
Battery .....	24 Hour Recharge 7-10 Year Life Expectancy
Weight .....	2.5 lbs.
Approval .....	UL and CUL Listed



## FEATURES

- Will cold start and operate all specified lamps
- Long life high temperature recyclable Ni-Cad battery
- Galvanized steel case
- Includes test switch and charge indicator accessory kit
- For use with switched or unswitched fixtures
- **5-Year Warranty.** See Warranty Page for details.
- Rated for use in damp locations, plenum, and enclosed and gasketed fixtures
- Meets or exceeds all NEC, IBC, and Life Safety Code Emergency Lighting Requirements
- RoHS Compliant
- International Voltage Models available

## DIMENSIONS

9.5" x 2.4" x 1.5" (mounting center 9.0")

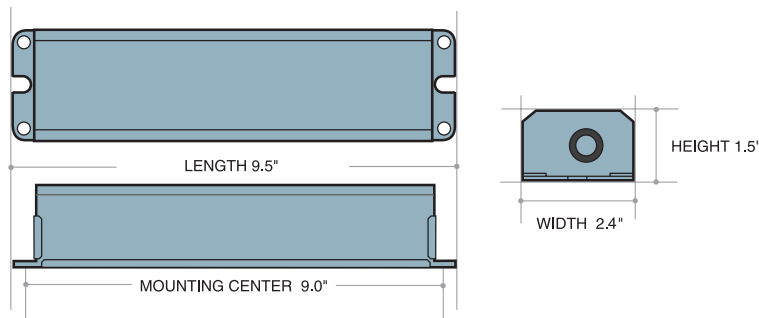

FLUORESCENT

COMPACT

# I-13-EM-B

FLUORESCENT EMERGENCY BALLAST FOR 2-PIN LAMPS

## OPTIONS

### TEST KIT CONFIGURATION

- TWO-PIECE TEST SWITCH AND CHARGE INDICATOR

### MOUNTING CONFIGURATION

- EM-B

### VOLTAGE RATINGS

- 120/277V 60HZ (STANDARD)
- 220V 50HZ
- 240V 60HZ
- 120V 50HZ

## INITIAL LUMEN RATINGS

LAMP	1 LAMP
7W PL CF 2-pin	350
9W PL CF 2-pin	500
13W PL CF 2-pin	650

## REMOTE MOUNTING

When battery packs are remote mounted, consult Customer Service for the maximum allowable distance between the battery pack and lamp(s).